



**Mini Tank water heater
Electric undersink
Water heaters**

GL 2.5 - GL 4 - GL 6+

IMPORTANT SAFETY INSTRUCTIONS

WARNING

When using electrical appliances, safety precautions to reduce the risk of fire, electric shock or injury to persons should be followed, including:

1. **READ ALL INSTRUCTIONS BEFORE USING THIS WATER HEATER.**
2. This water heater must be grounded.
3. Install or locate this water heater only in accordance with the provided installation instructions.
4. Use this water heater only for its intended use as described in this manual.
5. Contact a qualified electrician to have unit properly installed.
6. As with any appliance, close supervision is necessary when used by children.
7. Do not operate this water heater if it is not working properly or if it has been damaged or dropped.
8. This water heater should be serviced only by qualified service personnel. Contact a service facility for examination, repair or adjustment.
9. Failure to service the anode rod at least once a year could cause the tank to fail and leak.

KEEP THESE INSTRUCTIONS AT HAND **SAVE THESE INSTRUCTIONS**

Technical data

MODEL		GL 2.5	GL 4	GL 6+
Capacity	gallons	2.5	4	6
Voltage	Vac	110/120 for each model		
Power at 120 Vac	Watts	1500	1500	1500
Maximum Water pressure	psi	150	150	150
Weight	Lbs	15.5	17.3	29.5
Amperage	Amps	12.50 for each model		
Phases		1	1	1

WARNING

The installer should review the contents of this manual with the owner upon completion of installation, and the manual should be left with the owner and placed in a location close to the installation.

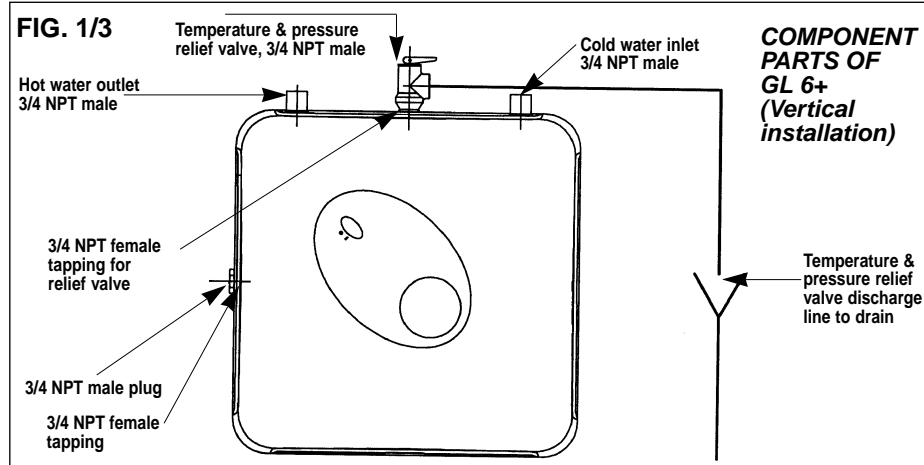
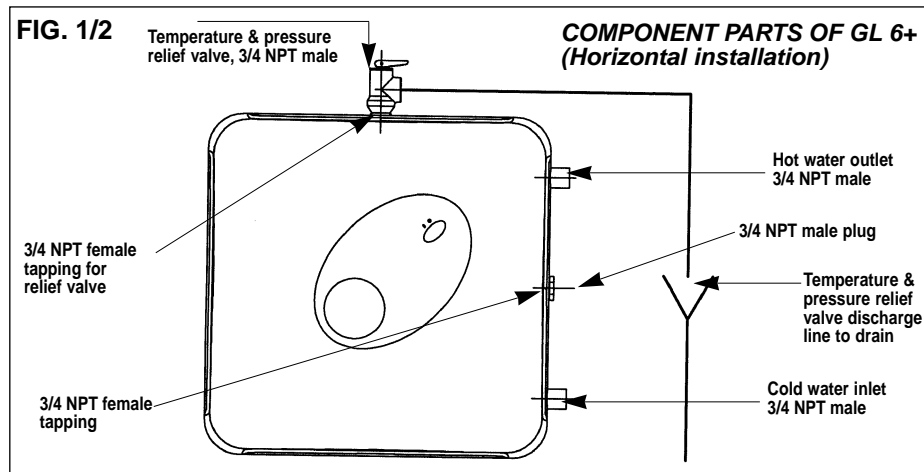
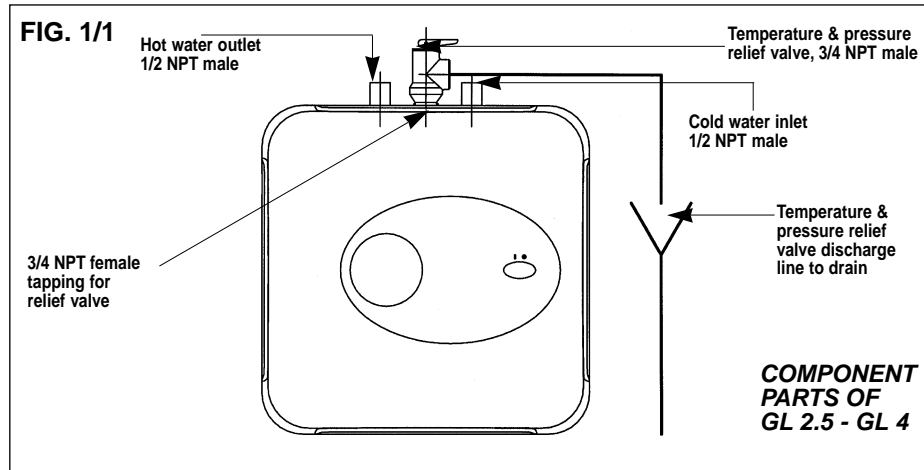

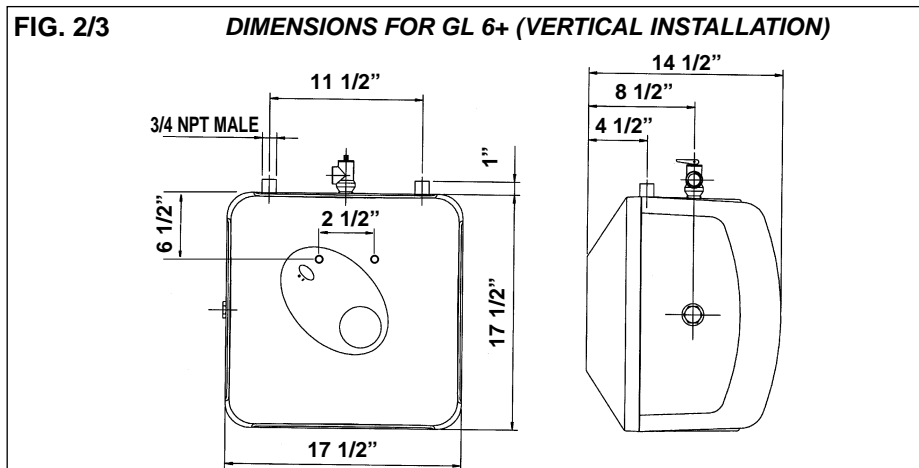
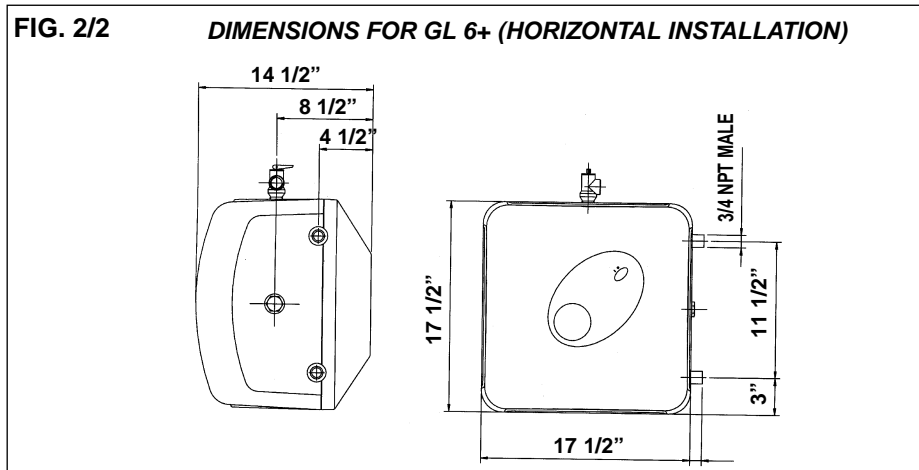
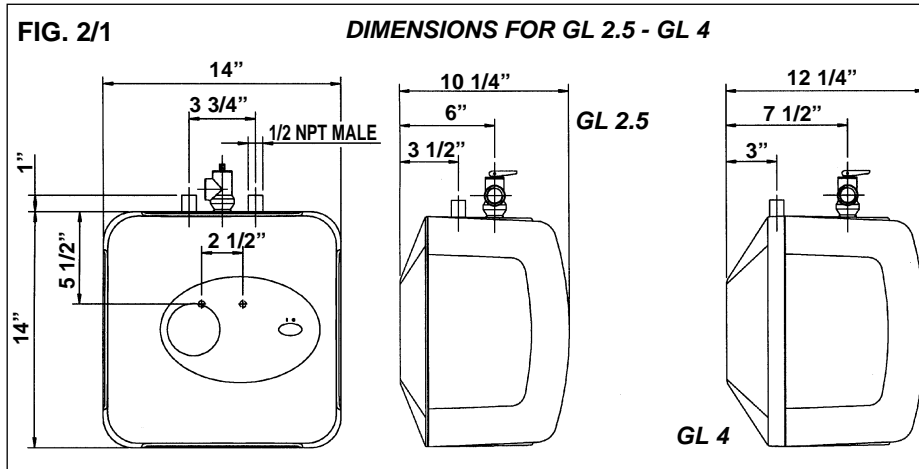

General remarks

- CAUTION** The manufacturer cannot be responsible for the damages caused by improper installation or by failure to follow instructions in this pamphlet. Comply with the installation instructions before completing electric connection.
- CAUTION** The thermostat has been pre-set at the factory between 41°C (105° F) and 45° C (113° F).
- CAUTION** Hydrogen gas can be produced in a hot water system served by this heater that has not been used for a long period of time (generally 2 weeks or more). Hydrogen gas is extremely flammable. To reduce the risk of injury under these conditions, it is recommended that the hot water faucet be opened for several minutes at the kitchen sink before using any electrical appliance connected to the hot water system. If hydrogen gas is present, there will probably be an unusual sound such as air escaping through the pipe as the water begins to flow. There should be no smoking or open flame near the faucet at this time.

Installation instructions

MODEL GL 6+

The GL 6+ water heater can be installed under the sink.

**Wall mounting
(only for vertical installation)**

Fasten the supplied mounting bracket to the wall. Use screws that are suitable for the wall material and the weight of the heater. Hang the water heater on the bracket. Tug down wards on the heater to ensure that both "fingers" of the bracket are seated in the mounting slots. Confirm water piping orientation before wall mounting.

Floor Mounting

Heater can sit on floor. Confirm water piping orientation before locating on floor location.

Wiring

The GL6+ needs to be wired with 12 GA. wire to a minimum 20 amp/ maximum 20 amp branch circuit. (Remove cover plate **V** (fig. 3/4) using a thin screw-driver operating on point **W** (fig. 3/4). Unscrew the screw below and lift the cover **C** (fig. 3/4). When reassembling work in the opposite way being careful to insert first the tongue of the cover into the slot.) Insert 12 AWG through conduit at rear of heater. Secure internal wire connector below thermostat (fig. 3/3) and connect wiring to right side of thermostat control. (+) to lower terminal marked "L", neutral to upper terminal marked "N". Unit must be grounded **T** (fig. 3/3).

Pipe connections

Connect the cold water inlet pipe to the inlet nipple (marked with a blue ring) and the hot water outlet pipe to the outlet nipple (marked with a red ring).
The model GL 6+ can be piped horizontally from the side or vertically from the top. If you wish to install the unit horizontally, with the piping connections on the right side, you will have to be certain the tap between the two water tapplings is plugged, the supplied Temperature and Pressure Relief Valve will need to be installed on top.
If you wish to install the unit vertically, with the piping connections on top, you will have to be certain the tap on the side is plugged, the supplied Temperature and Pressure Relief Valve will need to be installed on top.

MODEL GL 2.5 - GL 4

The GL 2.5 and GL 4 water heaters can be installed under the sink.

Wall mounting

Fasten the supplied mounting bracket to the wall. Use screws that are suitable for the wall material and the weight of the heater. Hang the water heater on the bracket. Tug down wards on the heater to ensure that both "fingers" of the bracket are seated in the mounting slots.

Floor Mounting

Heater can sit on floor.

Pipe connections

Connect the cold water inlet pipe to the inlet nipple (marked with a blue ring) and the hot water outlet pipe to the outlet nipple (marked with a red ring).

CAUTION

To reduce the risk of excessive pressures and temperatures in this water heater, install the supplied temperature and pressure protective equipment required by local codes but not less than a combination temperature and pressure relief valve certified by a nationally recognized testing laboratory that maintains periodic inspection of production of listed equipment or materials, as meeting the requirements for Relief Valves and Automatic Gas Shut-off Devices for Hot Water Supply Systems, ANSI Z21.22. This valve must be marked with a maximum set pressure not to exceed the marked maximum working pressure of the water heater. Install the valve in the opening provided and marked for this purpose in the water heater, and orient it or provide tubing so that any discharge from the valve will exit within 6 inches above, or at any distance below, the structural floor, and cannot contact any live electrical part. The discharge opening must not be blocked or reduced in size under any circumstances.

Closed system thermal expansion

Periodic discharge of the temperature and pressure relief valve or failure of the element gasket may be due to thermal expansion in a closed water supply system. The water utility supply meter may contain a check valve, backflow preventer or water pressure reducing valve which will create a closed water system. During the heating cycle of the water heater, the water expands causing pressure inside the water heater to increase. The temperature and pressure relief valve may discharge hot water under these conditions which results in a loss of energy and a build-up of lime on the relief valve seat.

To prevent this from happening, there are two recommendations:

1. Install a diaphragm-type expansion tank that is suitable for potable water on the cold water supply line. The expansion tank must have a minimum capacity of 1.5 U.S. gallons for every 50 gallons of stored water.
2. Install a 125 PSI pressure relief valve in the cold water supply line. Make sure the discharge of this valve is directed to an open drain and protected from freezing. Contact the local water supplier or plumbing inspector for information on how to control this situation. Do not plug the temperature and pressure relief valve.

Instructions for use

Starting and testing

Before connecting the power, fill the tank and system with water and check for leaks. To be certain that all air is out of the water system, open the hot water faucets on your fixtures until constant water flows from them otherwise damage to the element may occur.

To start the heating cycle:

- A) first make sure tank is full. Otherwise the heating element may be damaged.
- B) the red light will come on and remain on until that temperature has been reached, at which point the light will go off, but will automatically come back on when the water temperature drops below the setting chosen.

Temperature Setting

After installation check the water temperature. If adjustment is necessary remove front cover to adjust thermostat **D** (fig. 3/5 - clockwise to increase the temperature and anticlockwise to decrease it).

To reach the thermostat lift the plate **V** using a thin screw-driver operating on point **W** (fig. 3/4). Unscrew the screw below and lift the cover **C**. When reassembling work in the opposite way being careful to insert first the tongue of the cover into the slot.

Maintenance instructions

Note: Do not attempt to repair this water heater yourself. Call a service person for assistance. Always turn off the power supply to the heater prior to servicing or draining the heater.

PERIODIC MAINTENANCE AND PARTS REPLACEMENT

Note: For most of these operations, the water will have to be drained from the heater. For all of these operations the power supply needs to be shut off and the front cover removed.

Remove cover plate **V** (fig. 3/4) using a thin screw-driver operating on point **W** (fig. 3/4). Unscrew the screw below and lift the cover **C** (fig. 3/4). When reassembling work in the opposite way being careful to insert first the tongue of the cover into the slot.

Draining the Heater

- 1) If the heater has been installed with flexible hoses, shut off the power supply and turn the heater upside down over a sink to drain the water out of it, OR
- 2) If the heater has been installed with rigid piping, siphon the water out through any (lower) service valve on the (inlet side). Keep a hot water faucet open while siphoning the water out, OR
- 3) If the heater has been installed with flexible hoses, it can also be emptied by siphoning through the inlet side hose. Keep a hot water faucet open while siphoning.

Removing the heating element

1. Turn off power supply and drain the heater (see previous section).
2. Remove the front cover plate, disconnect terminals **X**, **Y** and **T** (fig. 3/3).
3. Unscrew the 4 heating element retaining nuts **F** (fig. 3/3).
4. Remove the element. **G** (fig. 3/1).

Descaling the heating element

Scale deposits can affect the heating capability of the element. Heavy scale can even cause the element to burn out. The element can be descaled either chemically or manually:

- A)** Soak the element in white vinegar or other descaling solution. Once descaled, rinse well with fresh water, to which you should add some baking soda, OR
- B)** Once the element has dried up, use a soft brush (non metallic to prevent damaging the stainless steel sheath) on element. Brush the dried mineral off. Reinstall the element with gasket and make the wire connections.
- C)** Replace anode rod if considerably shorter than diagram.

WARNING: make sure the tank has been refilled with water before restoring power.

REPLACEMENT OF PARTS

Changing the anode rod

The anode rod (**N** fig. 3/2) helps protect the tank against corrosion. Depending on the water condition, the magnesium anode rod may need to be changed every year or so. Galvanic and electrolytic corrosion can destroy a tank if the anode rod is "spent". Rusty water is usually an indication of a "spent" anode rod. If rusty water is present, examine anode rod immediately. Rapid degradation of the anode rod (less than 1 year) may indicate the presence of galvanic corrosion due to "stray" direct current. In this case, it may be necessary to add a "grounding strap" from the Ariston tank to the copper plumbing.

1. Turn off the power supply and drain the heater (see previous section).
2. Remove heating element (see previous section).
3. Remove and replace the anode rod **N** (fig. 3/2).
4. Refill tank with water before restoring power.

Changing the heating element

1. Turn off power supply and drain the heater (see previous section).
2. Remove the heating element (see section on **Removing the Heating Element**).
3. Install new element with gasket, making sure the gasket and element are positioned correctly. Tighten the retaining nuts and make the wire connections.
4. **Refill tank with water before restoring power.**

Changing the thermostat

1. Turn off power supply.
2. Disconnect the 2 push/pull type wires on thermostat.
3. Loosen the two brass screws at right side of thermostat and pull wires out.
4. Unscrew and remove the two phillips screws holding the thermostat down.
5. Install new thermostat and re-attach wiring and screws.

Resetting High Limit Switch

Occasionally, the high temperature limit shut off device may trigger and shut the system down. This occurs when water temperature exceeds 190° F and shuts off power to the heating element. The shut off device may also trigger from a power outage or electrical storm.

To reset:

- 1) **IMPORTANT:** Disconnect heater from electrical power.
- 2) Remove front cover plate (**C** fig. 3/4).
- 3) Firmly press reset button (**B** fig. 3/5).
- 4) Replace cover plate, reconnect power.
- 5) **IMPORTANT:** Check the operation of the thermostat, turn temperature dial from high to low, if the red light does not go off on low setting, turn off power supply and call a service person to replace thermostat.
- 6) If the system works, place dial setting to desired setting.

Note: a lower setting is more economical, and reduces the risk of scalding.

CAUTION: Call a technician if the high limit needs to be reset frequently.

Troubleshooting

Water does not get hot

1. Make sure the power supply is on and working.
2. If light does not come on, check that the reset button is pushed in; follow steps from previous section.
3. If the indicator light works properly but temperature does not get hot at a tap, test for a plumbing crossover; shut off cold supply to heater and open hot water tap. There should be no water flowing. Any continued flow indicates a crossover which will effect the temperature and will need to be corrected.
4. Replace heating element (see previous section on changing the heating element).

Light not on

1. If the light does not come on, but water gets hot, check for faulty bulb.
2. Check reset button; follow steps from previous section.

Brown water

1. Brown or rusty water indicates a “spent” anode rod. Replace anode rod.

Odor in water

1. Smelly water could be due to an unusual reaction between local water and the heater's anode rod. Check anode rod.

Water is too hot

1. Remove cover plate and turn the temperature selector dial (**D** fig. 3/5) counter clockwise to lower temperature. If temperature never lowers then replace thermostat.

Water not hot enough

1. Under **Instructions for Use** see **Temperature Setting** instruction.

Leaking

1. Check water fittings and T & P fitting on top of tank.
2. Remove front cover and inspect heating element gasket.

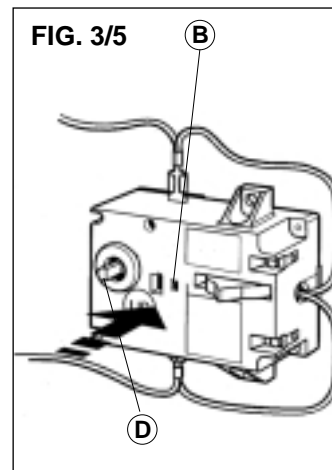
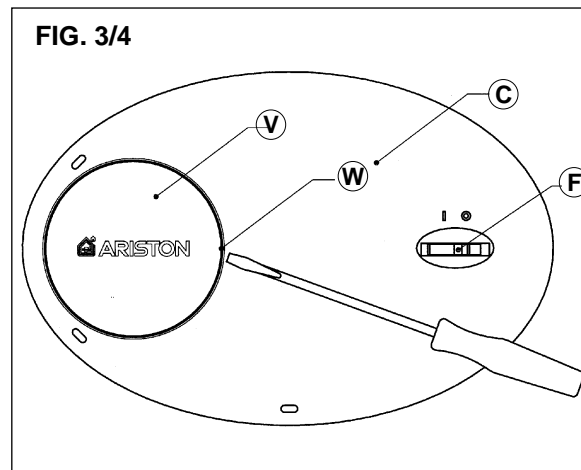
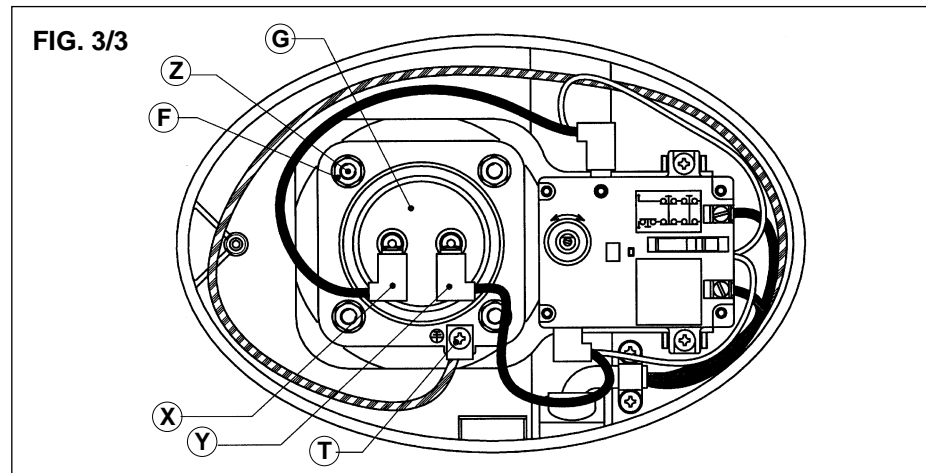
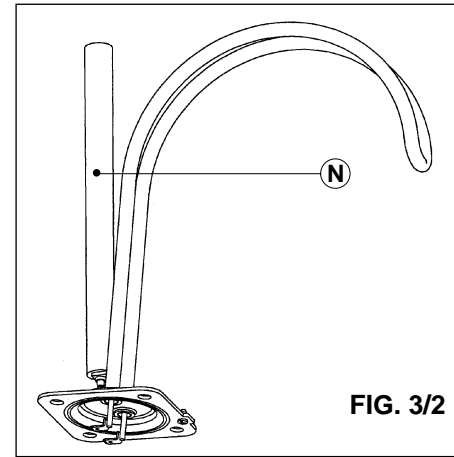
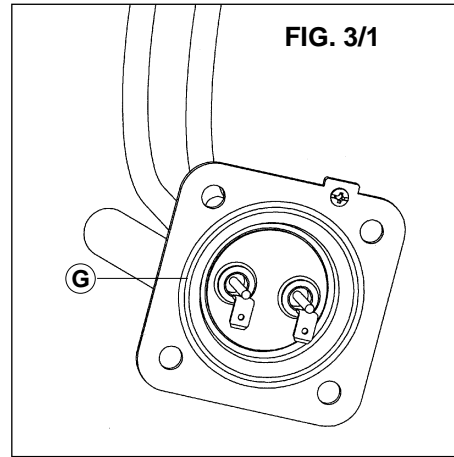

ARISTON • LIMITED 6 YEARS WARRANTY

COVERAGE

ARISTON, THROUGH ITS U.S. DISTRIBUTOR CONTROLLED ENERGY CORP., (hereinafter CEC) guarantees this water heater to the Owner (hereinafter "Owner") of the water heater at the original installation location against defects in material and workmanship for the periods specified below.

WARRANTY PERIOD

1. **The inner Tank** - If the inner tank leaks within six (6) years from the date of original installation of the water heater, because of a defect in material or workmanship, CEC will furnish to such Owner a new heater of the then prevailing comparable model.

2. **Any Component Part Other than The Original Inner Tank** - If any component part (other than the inner tank) proven to be defective in material or workmanship within one (1) year from the date of original installation of the water heater, CEC will furnish the Owner with a replacement of the defective part(s).

3. **Verification of Date of Original Installation** - When Owner cannot verify or document the original date of installation, the warranty period begins on the date of manufacture marked on the tag affixed to the water heater.

EXCLUSIONS

1. THIS LIMITED WARRANTY SHALL BE THE EXCLUSIVE WARRANTY MADE BY THE MANUFACTURER AND IS MADE IN LIEU OF ALL OTHER WARRANTIES, EXPRESSED OR IMPLIED (WHETHER WRITTEN OR ORAL), INCLUDING, BUT NOT LIMITED TO, WARRANTIES OF MERCHANTABILITY AND FITNESS FOR A PARTICULAR PURPOSE.

2. The Manufacturer shall not be liable for any incidental, consequential, special or contingent damages or expenses arising, directly or indirectly, from any defect in the water heater or the use of the water heater.

3. The Manufacturer shall not be liable for any water damage arising, directly or indirectly, from any defect in the water heater component part(s) or from its use.

4. Manufacturer shall not be liable under this warranty if:

- a) The water heater or any of its component parts has been subject to misuse, alteration, neglect or accident, or
- b) The water heater has not been installed in accordance with the applicable local plumbing and/or building code(s) and/or regulation(s), or
- c) The water heater has not been installed in accordance with the printed manufacturer's instructions, or
- d) The water heater is not continuously

supplied with potable water.

5. The OWNER and not the Manufacturer or his representative shall be liable for and shall pay for all field charges for labor or other expenses incurred in the removal and/or repair of the product or any expense incurred by the owner in order to repair the product.

SOME STATES DO NOT ALLOW THE EXCLUSION OR LIMITATION OF INCIDENTAL OR CONSEQUENTIAL DAMAGES, SO THE ABOVE LIMITATION OR EXCLUSION MAY NOT APPLY TO YOU. THIS WARRANTY GIVES YOU SPECIFIC LEGAL RIGHTS AND YOU MAY ALSO HAVE OTHER RIGHTS WHICH MAY VARY FROM STATE TO STATE.

IMPORTANT: OWNER SHALL KEEP THIS MAKE A CLAIM

NOTE: A water heater should be installed in such a manner that if it should leak, the resulting flow of water will not cause damage to the area in which it is installed.

HOW THE OWNER CAN SECURE SERVICE OR MAKE A CLAIM

1. Owner should contact the dealer who sold the water heater covered by this warranty or
2. Owner should submit the warranty claim directly to CEC at the address listed below, and they will arrange for the handling of the claim
3. Whenever any inquiry or service request is made, be sure to include the water heater model number the date of manufacture, date of installation, Dealer's name and the watts and voltage.
4. When returning the water heater or component part(s), they must be individually tagged and identified with the Returned Goods Authorization # issued by CEC and shipped prepaid to CEC at the address below.



COMMON SENSE HEAT & HOT WATER TECHNOLOGY

Controlled Energy Corp.
340 Mad River Park
Waitsfield, VT 05673
800-642-3111
802-496-4436
Fax 802 496-6924

www.controlledenergy.com

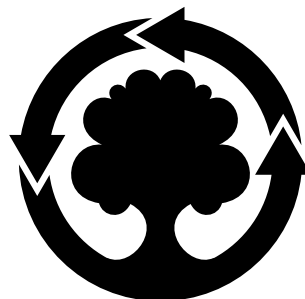

MTS MAKES USE OF
RECYCLED PAPER



6K88 LISTED

MTS
GROUP

Merloni TermoSanitari SpA

Viale Aristide Merloni, 45
60044 Fabriano (AN)
Tel. 0732.6011
Telefax. 0732.602331
Telex 560160
<http://www.mtsgroup.net>



COMMON SENSE HEAT & HOT WATER TECHNOLOGY

Controlled Energy Corp.
340 Mad River Park
Waitsfield, VT 05673
800-642-3111
802-496-4436
Fax 802 496-6924
www.controlledenergy.com

29.1.60.542.1.01 0900 Litograf s.r.l.