



Installation and Operating Instructions

MOBIUS WATER HEATER™

MODEL T - M1

**Instantaneous Tankless Gas Water Heater
Suitable for
Potable water heating and Space heating**

Indoor and Outdoor installation



FEATURES

- θ ENDLESS HOT WATER SUPPLY
- θ ON-DEMAND
- θ PILOT LESS SYSTEM
- θ COMPACT, SAVE SPACE
- θ COMPUTER CONTROL
- θ COMPUTERIZED SAFTY
- θ CONSERVES ENERGY
- θ FULL CAPABILITY FOR MANIFOLD

Store these instructions next to the hot water heater for reference purposes.



TAKAGI INDUSTRIAL CO. USA Inc.
6 Goddard, Irvine, CA 92618
Tel. (949) 453 - 8388, FAX. (949) 453-8498
<http://www.takagi-usa.com>

FOR YOUR SAFETY - READ BEFORE OPERATING

Thank you for purchasing this water heater. Properly installed and maintained, it should give you years of trouble free service. Read this installation manual before system install to application whether with or without experience with Takagi Tankless Gas water heater.

Do not copy this installation manual without consent from Takagi Industrial Co. USA Inc. Copy Right 2002, Takagi Industrial Co. USA Inc.

FOR YOUR SAFETY - This product must be installed and serviced by a professional service trained technician. Improper installation and/or operation could create carbon monoxide gas and flue gases, which could cause serious injury or death. Improper installation and/or operation will void the warranty.

WARNING: If the information in this manual is not followed exactly, a fire or explosion may result, causing property damage, personal injury or death.

- Do not store or use gasoline or other flammables, vapors and liquids in the vicinity of this or any other appliance.
- WHAT TO DO IF YOU SMELL GAS
 - Do not try light any appliance.
 - Do not touch any electrical switch, also do not use any phone in your building.
 - Immediately call your gas supplier from a neighbor's phone. Follow the gas supplier's instructions.
 - If you cannot reach your gas supplier, call the fire department.
- Only a Licensed contractor or plumber, trained technician, certified installer and service agency should perform installation and/or service this unit otherwise warranty will void from manufacture.

WARNING: To install this unit correctly, you must follow the procedures listed in this manual. Failure to do so will void any and all warranties offered by Takagi Industrial Co. USA, Inc.

Do not make any changes to the water heater, or to its gas controls, gas orifices, wiring or draft. Any modifications may void the warranty. If the unit must be modified because of special conditions or circumstances, consult the manufacture or factory representative before making any changes.

CONTENTS

For Your Safety	4
Operation	5
• General	5
• Temperature	5
• Freeze Prevent Device	6
• Winterizing	6
Installation	7
• General	7
• Accessories	8
• Optional Items	8
• Outdoor Installation	8
• Indoor Installation	9
• Combustion Air Supply	9
• Venting Instructions	10
• Gas Supply	12
• Water Connection	13
• Pressure Relief Valve	14
• Electrical Connection	14
Starting Operation	15
Operating Instruction	15
Wiring Diagram	17
For your Safety	18
Application	20
• Space Heating	20
• Dual-purpose heating	21
• Storage Tank	22
• Re-Circulation	22
Temperature Setting	23
Manifold Multi System	23
Maintenance and Service	27
Error codes	28, 32
Trouble Shooting	29
Component Diagram	33
Part List	37
Output temperature Chart	39

SPECIFICATIONS

Natural Gas Input	Min. 25,000 Btu Max. 235,000 Btu
LPG Input	Min. 25,000 Btu Max. 225,000 Btu
Gas Connection	¾" NPT
Water Connection	¾" NPT
Water Pressure	Min. 15 psi Max. 150 psi
Natural Gas Pressure Inlet	Min. 5" WC Max. 10.5" WC
LP Gas Pressure Inlet	Min. 11" WC Max. 14" WC
Manifold Pressure	Natural 2.2" WC Propane 2.7" WC
Weight	70 lbs.
Dimensions	24.5"x16.5"x8.3"
Ignition	Electronic Ignition
Electrical Supply	AC 120 V

- Inlet gas pressure must not exceed the above maximum values.
- For gas pressures lower than 5" WC for natural gas and 11"WC for propane, call the manufacturer.
- Before installing in areas over 4,500 feet above sea level, contact the manufacturer for high altitude adjustment instructions.
- Check the rating plate to insure this product matches your specifications.
- Takagi - USA is constantly improving our products; therefore specifications are subject to change without prior notice.

INTRODUCTION

This manual provides information necessary for the installation, operation, and maintenance of the MOBIUS Model T-M1 water heater. This unit includes a power fan for power venting system, and an advanced electronic ignition system.

The model designation is listed on the rating plate, which is attached to the front of the water heater. Please read all application and installation procedures completely before doing the installation. If you have any problems or questions regarding this equipment, consult the Takagi Industrial Co. USA, Inc. or local factory representative. Experiences have shown that most operating problems are caused by improper installation (human error).

FOR YOUR SAFETY

FOR YOUR SAFETY, PLEASE READ THIS MANUAL CAREFULLY AND FOLLOW ALL DIRECTIONS.

1. Follow all local codes, or in the absence of local codes, follow the most recent edition of the National Fuel Gas Code, ANSI Z223.1/NFPA 54 in USA or the CGA standard, CAN/CGA B149.1 or .2 Installation Codes for Gas Burning Appliances in Canada.
2. Properly ground the unit in accordance with all local codes or in the absence of local codes, with the National Electrical Codes, ANSI/NFPA 70 in the USA or CSA standard C22.1 Canada Electrical Code Part 1 in Canada.
3. Carefully plan where you intend to install your MOBIUS Water Heater. Insure that your heater will have enough combustible air, proper ventilation, and locate your heater where water leakage will not do damage to surrounding areas. If there is a possibility of water damage, install a suitable drain pan under the unit, which will not restrict combustible airflow.
4. Check the rating plate for the correct gas type, gas pressure, water pressure, and electrical rating. If this unit does not match your requirements, do not install.
5. If any problem should occur, turn off all hot water taps and turn off the gas. Then call a

trained technician or Gas Company or manufacturer.

6. **WARNING:** Do not disconnect the electrical supply if the ambient temperatures will be reaching freezing. The Freeze Prevention Device only works if the unit has proper electrical power. The Freeze Prevention Device is rated for temperatures down to 5°F (-15°C) in a wind free environment. The wind chill factor will cause the MOBIUS Water Heater to freeze and be damaged at temperatures below 5°F (-15°C). Refer to the section on Winterizing and Freeze Prevention Device for more information. Warranty will not be covered if the heat exchanger is damaged by weather. Please read winterize section in this installation book.
7. **WARNING:** Before bathing or showering always check the water temperature. Do not leave children or infirm person unsupervised in the shower or bath. The water temperature is set at 140°F (60°C) from the factory to maximize the amount of hot water you can use without an optional temperature remote controller, Water temperature over 125°F can cause severe burns instantly or death from scalding.
8. **WARNING:** Do not use this appliance if any part has been contacted or been immersed water. Immediately call a certified, trained technician or manufacture to inspect and/or service the unit if necessary.
9. **WARNING:** Do not store or use gasoline or other flammables, vapors and liquids in the vicinity of this or any other appliance.
10. **WARNING:** Do not reverse the water and/or gas connections, this will damage the heat exchanger and can cause severe injury or death from scalds. Following the diagram below when installing your MOBIUS water heater.



RATING PLATE



Pressure relief Valve
HOT

COLD GAS

GENERAL

The MOBIUS Water Heater is an instantaneous, tankless water heater designed to supply endless hot water to your entire household and/or commercial hot water needs utilizing total efficiency. The principle behind the MOBIUS Water Heater is simple. Once you open a hot water tap, water flows through the MOBIUS Water heater. Once a minimum of 0.75 GPM is achieved the flow sensor automatically commands the computer to electronically turn on the fan, activate the electronic igniter and open the gas valve the computer monitors the water temperature, water flow rate, and gas flow the insure you get the right amount of hot water with the correct hot water temperature. After the burners are ignited the "fire on" lamp is lit. Computer will modulate gas supply to valve and water flow. 0.75 gallons per minute is required to turn the burners on, after the burners are ignited, the flow rate can be lowered to 0.6 gallons per minute to maintain and still keep the heater on. It is advisable to increase the cold tap rather than decreasing the hot tap to adjust the water temperature. Now as long as you have water,

gas and electricity, you will get an endless flow of hot water. Open a hot water tap to turn on your water heater. Close the tap to turn off your water heater.

Temperature

The temperature has been set at the factory Max. of 140° F (60° C). The computer will electronically control this temperature. Mix the cold water with hot to get the water temperature you desire. If desiring hot water temperature want other than factory setting temperature (140°F), please purchase the optional temperature remote controller, part No. TM-RE10. With this optional part TM-RE10 you can set the temperature from 95 ° F to 176 ° F, please carefully read the instructions prior to installation, failure to do so can damage the temperature controller and/or the water heaters onboard computer, which will void warranty.

WARNING: Temperatures above 125° F (52° C) can cause severe burns or death from scalding. Children, disabled and the elderly are at high risk of being injured. Feel the water temperature before bathing or showering. Do not leave children, disabled and the elderly without supervision. MOBIUS water heater will produce hot water based on setting temperature. Please refer to the temperature and gallons per minute chart on the back of this manual for your convenience.

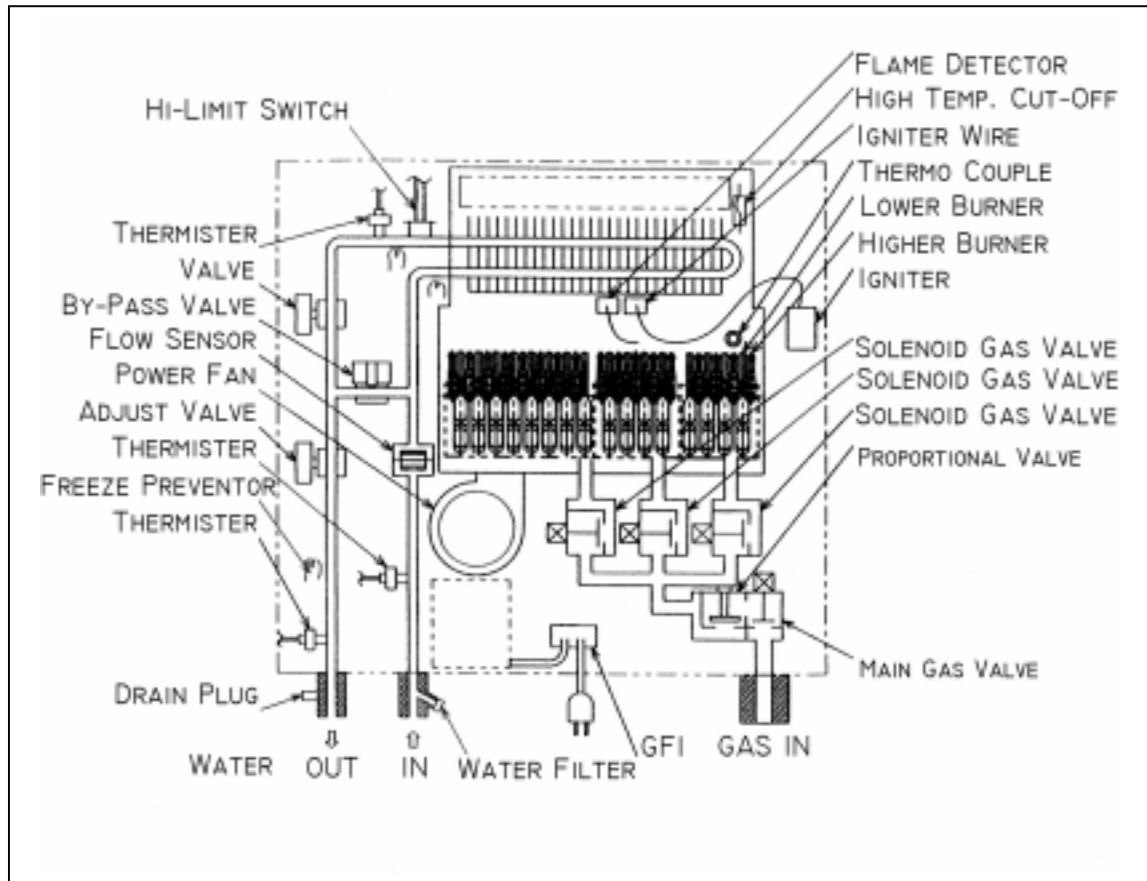

Freeze Prevention Devices

This unit comes equipped with heater blocks to prevent freezing which can damage the heat exchanger. For this freeze prevention system to operate there has to be electrical power to the unit. Damage to the heat exchanger caused by freezing due to electric power outage is not covered under warranty.

The freeze prevention devices will not work if the electrical power source is disconnected.

The unit has been rated for temperatures down to 5° F (-15° C) in a wind free environment. The wind chill factor will cause the unit to freeze at temperatures above 5° F (-15° C).

Do not install the water heater in an area with extremely cold weather, this will void warranty and Takagi-USA will not be held responsible for any damage occurring from such environment. For this purpose a back flow prevention kit (Part TK-TV03) is highly recommended for areas with freezing weather, to prevent freezing air from entering through

the exhaust venting when the water heater is on standby which can damage the heat exchanger.

CAUTION: The pipe heaters are located on the MOBIUS Water Heater only. Any hot or cold water pipes located outside of the unit will not be protected. Properly protect and insulate these pipes from freezing.

Winterizing

If you will not be using your heater for a long period of time or if the temperatures will drop below 5° F (-15° C) with the wind chill factor, turn off your heater and drain the unit of water. This will keep your unit from freezing and being damaged. Follow these instructions carefully:

1. Turn off the power supply to the Flash Water Heater.
2. Turn off the manual gas control valve located outside your heater.
3. Turn off the manual water shut off valve located on the water supply line.

4. Open all hot water taps in the house. (Bathroom, kitchen, laundry room, etc.). When the water flow has ceased, close all hot water taps.
5. Have a bucket or pan to catch the water from the units drain plugs. Remove the drain plugs to drain all the water out of the unit.
6. Wait a few minutes to ensure all water have drained from unit.
7. At this time please check the water filter located inside the cold inlet. With a tiny brush, clean the water filter of any calcium or debris which may have accumulated over time and reinsert the filter back into the cold water inlet.
8. Securely screw the drain plugs back into place.

Now when you want to use your heater again follow these steps:

Make sure all hot water taps are closed and the drain plugs are securely attached.

1. Purge the water line of debris.
2. Turn on the manual water control valve located on the water supply line.
3. Open all the hot water taps to verify water flows to the taps. Then close hot water taps.
4. Turn on the manual gas control valve located on the gas supply line.
5. Turn on the power supply to the MOBIUS Water Heater.

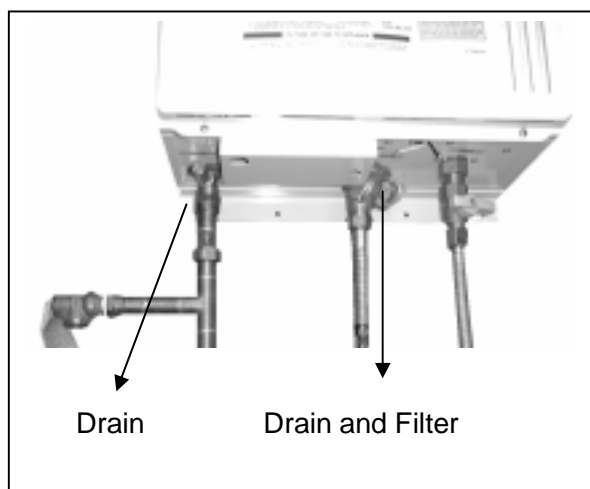

INSTALLATION

This section is for the installer. The installer is responsible for the correct installation of your MOBIUS Water Heater.

For Your Safety: Only a certified and trained service technician or qualified plumber may service or install your product.

General



All gas water heaters require careful and correct installation to insure safe and efficient operation. This manual must be followed exactly. Read the "For Your Safety" section in the beginning of this manual.

1. The regulator is preset at the factory, this is computer controlled and should not need adjustment.
2. Maintain proper space for servicing. Install the unit so that it can be connected or removed easily.
3. The electrical connection requires a means for switching off the power supply.
4. Avoid installing the unit in an area with high level of dust, sand, debris such as flour within a bakery shop which can become airborne can enter and buildup within the fan causing damage to the fan and/or burner. So please take precaution to prevent such foreign matter from entering the unit.
5. Impure particles from these objects may clog the air vent or reduce functions of the rotating fan and cause gas not to burn properly. Regular maintenance is recommended for these types of environment.
6. Do not install the unit where the exhaust vent is pointing into any opening in a building or where the noise may disturb your neighbors. Make sure the vent termination is 4' feet from a doorway or opening to prevent exhaust from entering.

Accessories

Check that all parts listed below were included with the unit.

Installation Manual, Warranty Card and Optional Part Information

PARTS NAME	SHAPE	NUMBER
Manual		1
Washers		4
Screws		4

Optional Items

1. TM-RE10 Temperature Remote Controller



The TM-RE10 Temperature Remote Controller has two functions, it allows the output temperature from the T-M1 to be adjusted within the range of 95 °F to 167 °F, and it also works as a diagnostic tool that will give a concise error code whenever there is a problem with the unit. The temperature options are 95°F, 100°F, 102°F, 104°F, 106°F, 108°F, 109°F, 111°F, 113°F, 115°F, 117°F, 122°F, 131°F, 140°F, 158°F, 167°F, and 176°F for 180°F. See the trouble shooting section for information on possible error codes.

2. TK-TV01 Vent Terminator



This terminator can be used where a T-M1 is going to be vented out through a wall. This is a CSA approved part of the unit. Connect a Category III Stainless vent pipe from the top of the unit to the backside of this terminator to exhaust flue gases through the wall without a

thimble. Install vent terminator in accordance with manufacturer's installation instructions and any applicable local codes.

3. TK-TV03 Vent Damper



The TK-TV03 Vent Damper prevents the backflow of air through the exhaust vent. This is CSA approved part of the unit. This helps prevent harmful exhaust gases from entering the home, as well as helping to prevent the units from freezing in areas where cold air can be blown into the exhaust system. Install vent damper according to manufacturer's installation instruction, and any applicable codes.

4. TM-TV06 Vent Cap



The TM-TV06 Vent Cap is for outdoor installation with the T-M1 water heater. The cap is installed on the top of the unit, instead of connecting an exhaust vent. The cap will prevent any debris that might be in the environment from entering the unit and causing damage or a fire hazard, as well as preventing rain or other weather from entering the unit.

OUTDOORS INSTALLATION

Follow all local codes and in the absence of local codes, follow the National Fuel Gas Code ANSI Z221.23 in USA or in Canada CAN/CGA B149.1 or .2 Installation of Gas Burning Appliances.

Locate the water heater in an open, unroofed area, and maintain the following minimum clearances. MOBIUS water heater is wall hanging installation only.

Piping side (Bottom)	12"
Front (Maintenance space)	24"
Back of heater	1"
Top of heater	36"

Do not install this water heater under an overhang, less than 3 feet from its top or eaves. The area under an overhang must be open to three sides

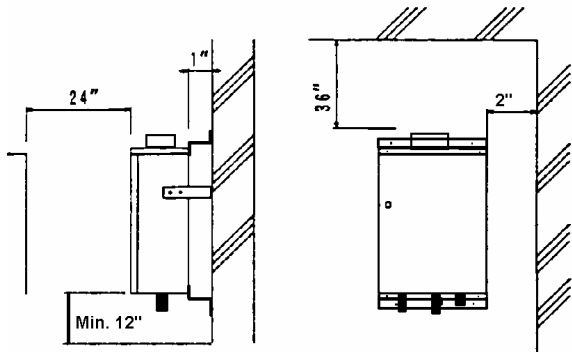

WARNING: Do not have the vent terminal pointing toward any opening into a building. Do not locate your heater in a pit or location where gas and water can accumulate.

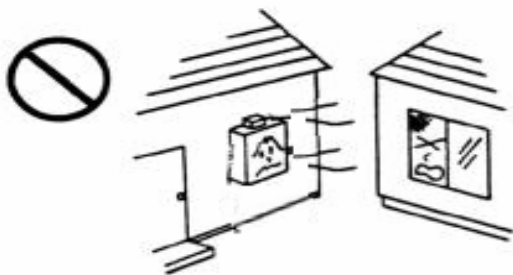

WARNING: Do not install the heater where water, debris, or flammable vapors may get into the flue terminal. This may cause damage to the heater. Warranty will void.

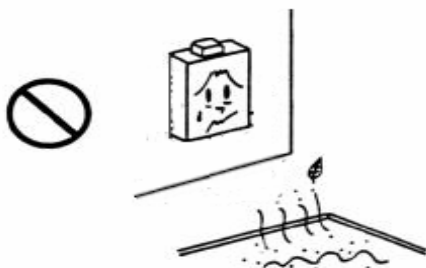

WARNING: In the USA, do not install the water heater vent terminator within 4 feet of any air intake opening into a building. In Canada do not install the water heater vent terminator within 10 feet of any air intake opening into a building.

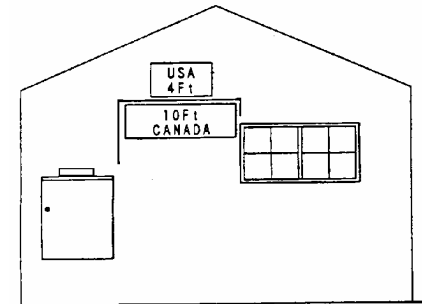

WARNING: Improper installation can cause nausea or asphyxiation from carbon monoxide and flue gases which could result in severe injury or death. Improper installation will void product warranty. For high altitude installation above 4,500 feet, Contact the manufacturer on how to handle this situation.

INDOOR INSTALLATION

Combustion Air Supply

The water heater location must provide enough air for proper combustion and ventilation of the surrounding area. See the latest edition of ANSI Standard Z223.1 or any your local codes that should be applicable. In general these requirements specify that if the unit is installed in a confined space, there must be permanent air supply opening.

Minimum recommended Air supply to water heater

Water heater size	Outside air area	Inside air area
Max. 235,000 BTU	59 Sq. IN	235 Sq. IN

Air Supply from Outside Building

When combustion air supplied directly through an outside wall, such as intake louvers openings into the dwelling, opening should give a minimum free area of one square inch per 4000 BTUH inputs of the total input rating of all appliances in the enclosed area.

Air Supply from Inside Building

When combustion air is supplied from inside the building, each opening of the closet door should have a minimum free area of one square inch per 1000 BTUH input of the total input rating of all appliance in the enclosed area. These openings should never be less than 100 Sq. in.

Combustion Air Supply from Make up air Fan.

MOBIUS water heater is equipped with a combustible air sensor that will shut off the MOBIUS when inadequate combustible air supply to unit is detected, MOBIUS water heater will stop until it has enough combustible air.

Any equipment, which exhausts air from the room around the unit, can deplete the combustion air supply. Such equipment can also reverse the action of the venting system. This could cause flue products to accumulate in the space where the water heater is installed. Additionally air must be supplied to compensate for any exhaust effect.

If a fan blower is used to supply air to the water heater or utility room, the installer should make sure it does not create drafts, which could cause nuisance shutdowns. If a blower is necessary to provide adequate combustion air to the water heater, a switch or equivalent devices must be wired into the water heater control circuit or proper devices to prevent the water heater from firing unless the blower is operating.

Venting Instructions

GENERAL

WARNING: Improper venting of this appliance can result in excessive levels of Carbon

Monoxide, which can result in severe personal injury or death.

This water heater must be vented in accordance with "Section Venting of Equipment", of the latest edition of the National Fuel Gas Code, ANSI Z223.1 and all applicable local building codes. In Canada, follow CAN/CGA installation codes.

general rules for venting the MOBIUS water heater.

1. Place the water heater as close as possible to the vent.
2. The vent collar on the water heater must be fastened directly to an unobstructed vent pipe.
3. Do not weld the vent pipe to the water heater collar. The weight of the stack must not rest on the water heater. The top of the water heater must be easily removable for normal service and inspection of the unit.
4. The water heater vent must not be connected to a fireplace, wood stove or other equipment.
5. Avoid terminating the water heater vent near any air-conditioning or air-supply fans. These fans can pick up the exhaust flue products from the water heater and return them to the building. This can create a health hazard.
6. Avoid using an oversized vent pipe or using extremely long runs of the pipe. This may cause excessive cooling and condensation of flue gases resulting in damage to the heat exchanger and are not covered under warranty.

Exhaust Vent

This water heater must be vented in accordance with the section on venting of equipment in the latest edition of the National Fuel Gas Code.

This is a Category III appliance, and must be vented accordingly. The vent system must be gas tight. All seams and joints must be sealed with silicone sealant or preferably high heat resistant, UL listed aluminum adhesive tape having a minimum temperature rating of 350° F. For best results, a horizontal vent system should be as short and straight as possible with Single wall Stainless steel vent pipe or

other approved, noncombustible, corrosion-resistant material. The following are UL listed manufacturers: ProTech Systems, FasNSeal, Z-Flex Inc. Z-Vent II and Heat-Fab Inc. Saf-T Vent. This unit requires 4" vent pipe. Connect the vent pipe to the unit so that it is sealed airtight. Follow the vent pipe manufacturer's instructions when installing the vent pipe. Do not common vent this appliance with any other vented appliance. The venting system must not exceed a length of 35 ft. minus 5 ft. for every elbow. Do not use more than 3 elbows.

When installing the vent system, all applicable national and local codes must be followed. If you install thimbles, fire stops or other protective devices, and they penetrate any combustible or noncombustible construction, be sure to follow all applicable national and local codes.

Fan assisted appliances should follow the requirement as indicated in the latest edition of ANSI Z233.1/NFPA 54.

The entire vent system must not exceed the size specified in table below.

Diameter	Max. No. of Elbow	Max. Vertical or Horizontal run in Length
4"	3 Ea.	35 ft

For each elbow added, deduct 5 ft. from max. Vent length.

No. of Elbows	Max. Vertical or Horizontal Length
0	35 ft.
1	30 ft.
2	25 ft.
3	20 ft.

When the horizontal vent run exceeds 5 ft. the following criteria must be observed;

- Attach a vertical pipe at least 2" high to the water heater outlet before the horizontal run.
- Support the vent run at 3 ft intervals with overhead hanger.
- Pitch up the vent run toward the vent terminal at a rate of 1/4" per foot.

Indoor installation clearance.

Piping side (Bottom of water heater)	Min. 12"
Front (Maintenance space)	Max. 24" Min. 4"
Back of heater	1"
Non piping sides (Side of water heater)	Min. 1"
Top of heater	12"

Vent Termination

A sidewall vent terminal must be used when the water heater is vented through a sidewall. Manufacturer's recommend to use Takagi - USA parts No.TK-TV01 as a vent terminator. The vent terminal provides a means of installing vent pipe through the building wall and must be located in accordance with ANSI Z223.1/NFPA 54, or in Canada CAN/CGA-B149 and local applicable codes.

Locate the vent terminal so that it cannot be blocked by snow. Most codes require that termination be at least 12 inches above grade, but the installer may determine if it should be higher depending on job site condition and applicable city code.

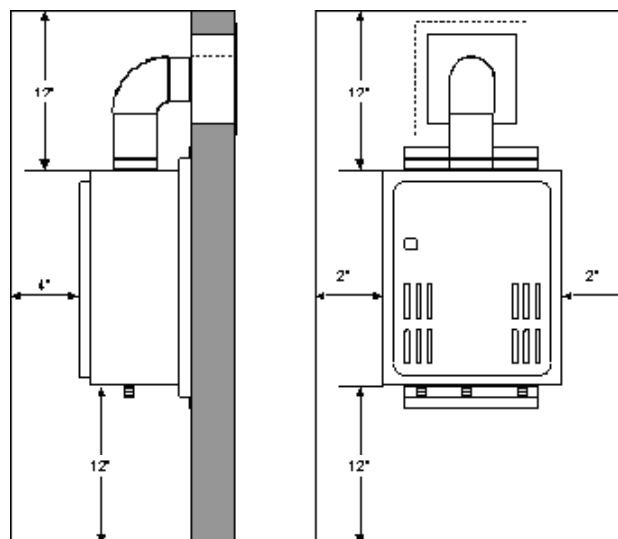

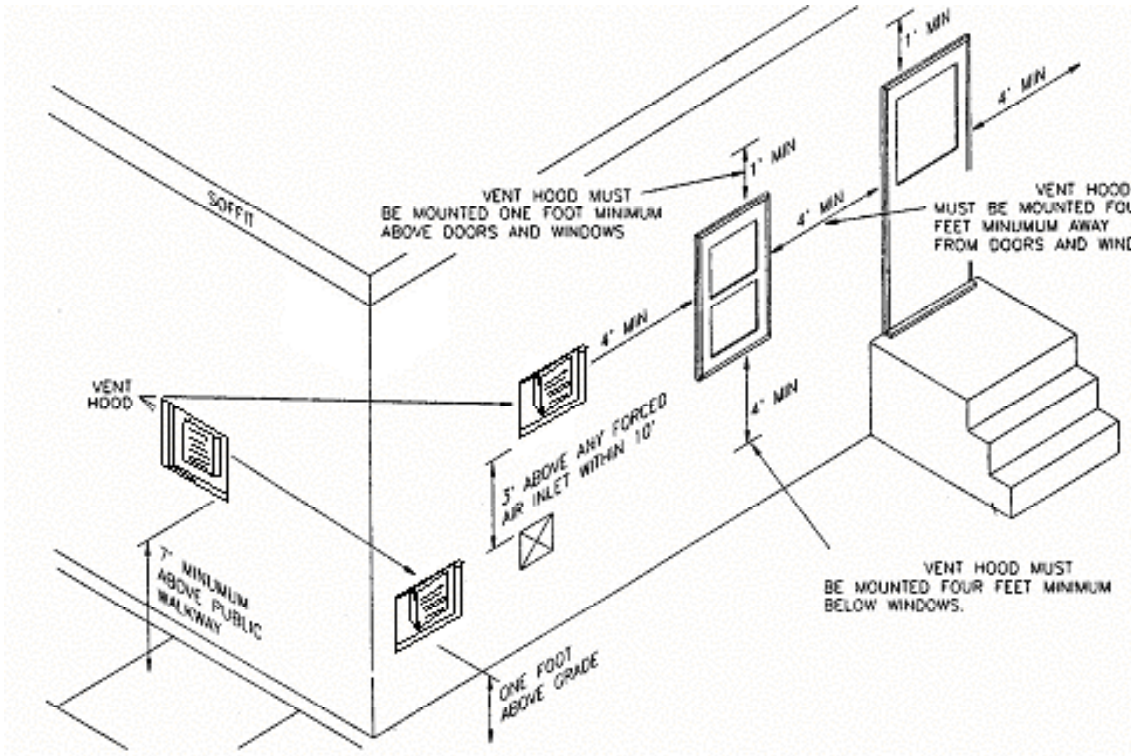

Installation vent terminator Clearance

Gas Supply and Gas Piping Sizing

This unit needs a manual gas control valve (System Shutoff Valve) that must be placed on the unit before it is connected to the gas line. Check the gas inlet pressure and the type of gas matches the rating plate located on your water heater. Insufficient gas pressure and volume will cause your MOBIUS Water Heater to be inefficient performance and not work properly. Sizing of gas piping system correctly following ANSI233.1/NFPA 54, or by local code.

The minimum and maximum inlet gas pressures are listed below

Natural Gas	Min. 5" WC Max. 10.5" WC
Propane Gas	Min. 11" WC Max. 14" WC

When measuring the inlet supply pressure, the water heater and all other gas appliances sharing the water heater gas supply line must be firing at maximum capacity. Maximum gas pressures must not exceed this value. Low gas pressure could be caused by an undersized gas pipe, this will cause the MOBIUS water

heater's performance to diminish and unable to reach maximum performance.

When connections are completed, check for gas leaks by applying soapy water to all gas fittings and connections. Soap bubbles are a sign of gas leaks.

This appliance and its individual shut-off valve must be isolated from the gas supply piping system by unplugging the unit and turning off the main gas valve during any pressure testing of the gas supply piping system at test pressures equal to or less than 1/2 Psi. The appliance and its gas connections must be leak tested before placing the unit in operation. Always use approved connectors to connect the unit to the gas line. Always purge the gas line of any debris before connecting to the heater gas inlet.

WARNING: Conversion of this unit from natural gas to propane or propane to natural gas cannot be done in the field. Contact your local retailer or distributor to get the correct unit for your gas type. Conversion done by anyone other than the manufacture will void any and all warranty.

Recommend Gas pipe size for MOBIUS Water Heater	
Distance from Gas Meter	Pipe Size (inches)
0' - 20'	3/4"
20' - 80'	1"
80' - 300'	1-1/4"

NOTE: These Tables are for Natural Gas (0.60 Specific Gravity) and based on Pressure Drop of 0.5 Inch water columns. This table is Gas piping supply straight to the water heater without any tab to other gas appliance.

Natural Gas Supply Piping

Based on 0.60 specific gravity for natural gas at .5" WC pressure drop
DOE standard is 1100 BTU per cubic ft. of natural gas

Pipe Size	Cubic Feet of Natural Gas													
	Length	10'	20'	30'	40'	50'	60'	70'	80'	90'	100'	125'	150'	200'
1/2"	174	119	96	82	73	66	61	56	53	50	44	40	34	
3/4"	363	249	200	171	152	138	127	118	111	104	93	84	72	
1"	684	470	377	323	286	259	239	222	208	197	174	158	135	
1 1/4"	1404	965	775	663	588	532	490	456	428	404	358	324	278	
1 1/2"	2103	1445	1161	993	880	798	734	683	641	605	536	486	416	
2"	4050	2784	2235	1913	1696	1536	1413	1315	1234	1165	1033	936	801	

Propane Supply Piping

Based on 11" WC supply pressure

Pipe Size	kBTU of Propane													
	Length	10'	20'	30'	40'	50'	60'	70'	80'	90'	100'	125'	150'	200'
1/2"	275	189	152	129	114	103	96	89	83	78	69	63	55	
3/4"	567	393	315	267	237	217	196	185	173	162	146	132	112	
1"	1071	732	590	504	448	409	378	346	322	307	275	252	213	
1 1/4"	2205	1496	1212	1039	913	834	771	724	677	630	567	511	440	
1 1/2"	3307	2299	1858	1559	1417	1275	1181	1086	1023	976	866	787	675	
2"	6221	4331	3465	2992	2646	2394	2205	2047	1921	1811	1606	1496	1260	

Water Connections

An approved manual water control valve (water shutoff valve) must be placed on the cold water supply line. All soldering materials and piping materials must be suitable with potable water.

If the water heater is installed in a closed water system, such as one having a backflow preventer in the cold water supply line, must be provided to control thermal expansion. Contact the water supplier or local plumbing inspector on how to control this situation.

After installation of water heater is complete, purge the water line to remove all the debris and air from the line. Failure to or not doing so may cause damage to the heater. There is a wire mesh filter to trap debris from entering your heater. This will need to be cleaned periodically for long life expectance.

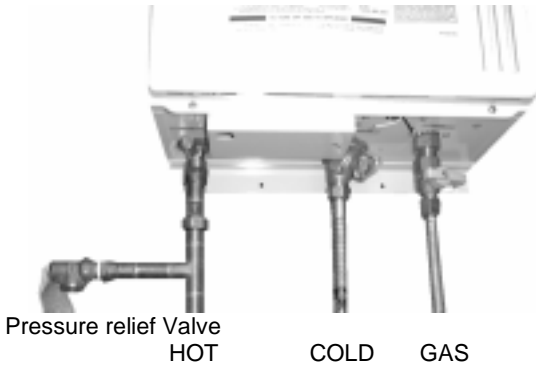

WARNING: Be careful not to reverse the hot outlet and cold supply line connections to the MOBIUS Water Heater. This will cause your heater to operate dangerously and void warranty. Make sure the hot and cold lines are connected properly. Refer to the FOR YOUR SAFETY section at the front of this manual.

PRESSURE RELIEF VALVE

The Mobius has a built Hi-Limit (high-temperature) shut off switch and no store hot water therefore only a “pressure only” relief valve is required.

This unit does not come with an approved pressure relief valve. An approved pressure relief valve must be installed on the hot water outlet. A “Tee” fitting should be used to attach the pressure relief valve. Then place the pressure relief valve 6” inches from water flow as shown in picture to prevent premature wear of relief valve. The pressure relief valve must meet and followed local code.

The discharge capacity must be at least 235,000 Btu/hr. The discharge piping for the pressure relief valve must be directed so that the hot water cannot splash on anyone or nearby equipment. Attach the run-off tube to the pressure relief valve, and run the end of the tube to within 6” from the floor. Do not install any reducing couplings, valves or any other type of restriction in this line. This run-off tube must be installed to allow free and complete drainage of both the valve and the run-off tube.

If the pressure relief valve on the appliance discharges periodically, this may be due to the thermal expansion in a closed water supply system or defective pressure relief valve, replace a new pressure relief valve. Contact

the water supplier or local plumbing inspector on how to correct this situation.

The pressure relief valve must be manually operated once a year to check for correct operation.

Should overheating occur or gas supply fail to shut off, turn off the manual gas control valve to the appliance.



Pressure Valve

CAUTION: Only the pipes within the heater are protected on the MOBIUS Water Heater. Any hot or cold water pipes located outside of the unit will not be protected. Properly protect and insulate these pipes from freezing.

Electrical Connections

WARNING: The heater must be electrically grounded. Follow the requirements of the local authority having jurisdiction. In the absence of such requirements, follow the latest edition of the National Electrical Code ANSI/NFPA 70 in the U.S., or the latest edition of CSA C22.1 Canadian Electrical Code, Part 1, in Canada. Do not rely on the gas or water piping to ground the metal parts of the water heater. Plastic pipe or dielectric unions may isolate the water heater electrically. Service and maintenance personnel who work on or around the water heater may be standing on wet floors, and could be electrocuted by an un-grounded water heater.

CAUTION: Label all wires prior to disconnection when servicing controls. Wiring error can cause improper and dangerous operation. Verify proper operation after servicing.

The MOBIUS water heater requires an electrical power supply from 120 VAC 60 Hz circuit and be properly grounded.

- A means for switching on/off the 120 VAC power supply must be provided for service reasons.
- Wire the heater exactly as shown in the wiring diagram.
- A green screw is provided in the junction box for grounding connection.

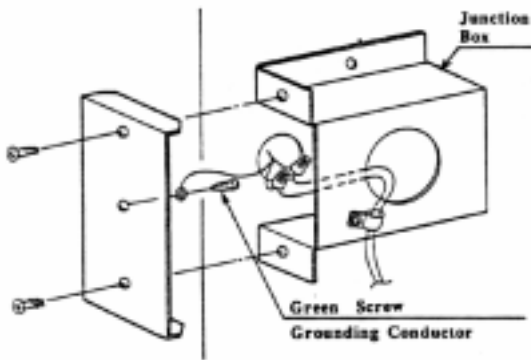

Refer to the wiring diagram. Wiring diagrams are also located on the inside panel of the appliance.

Starting Operation

For your safety please read before start and/or operating.

- This water heater does not have a pilot. It is equipped with an electronic ignition device, which automatically lights the burner. Do not try to light the burner by hand.
- Before operating, smell all around the water heater area for gas leaking. Be sure to smell next to the floor because some gas is heavier than air and will settle towards the floor.
- Use only your hand to turn the gas valve knob. Never use tools. If the knob will not turn by hand, do not try to repair it, call a qualified service technician. Force or attempted repair may result in a fire or explosion due to the gas leaking.
- Do not use this water heater if any part has been under water. Immediately call a qualified service technician to inspect the water heater and to replace any parts that has been under water.

WHAT TO DO IF YOU SMELL THE GAS!

1. Do not try to start the water heater.
2. Do not touch any electric switch; do not use any phone in your building.
3. Immediately call your gas supplier from a neighbor's phone. Follow the gas supplier's instructions.
4. If you cannot reach your gas supplier, call the fire department.

Operating Instructions

The MOBIUS Water Heater is an instantaneous, tankless water heater designed to supply your entire household and/or commercial hot water needs utilizing total efficiency. The principle behind the MOBIUS Water Heater is simple. Once you open a hot water tap, water flows through the MOBIUS Water heater. The water flow sensor automatically commands the computer to electronically ignite the burners and the computer monitors the water temperature, water flow rate, and gas flow to insure you get the right amount of hot water with right temperature hot water. After the burners have ignited the "fire on" lamp is lit. Computer will modulate gas supply to valve and water flow. 0.75 gallons per minute is required to turn the burners on, after the burners are ignited, the flow rate can be lowered to 0.6 gallons per minute to maintain and still keep the heater on. Now as long as you have water, gas and electricity, you will get an endless hot water. Open a hot water tap to turn on your water heater. Close the hot water tap to turn off your water heater.

Normal Operation

To Turn on Your MOBIUS water heater.

1. Open a hot water tap.
2. Burners ignite. "Fire On" lamp is lit.



3. Mix with cold water with the hot to get the correct temperature water.

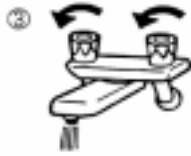

To Turn off your Mobius water heater

1. Close the hot water tap



“Fire On” lamp extinguishes.

FLOW

The flow rate through the Mobius is limited to a maximum of 9.6 GPM. The temperature setting, along with the supply temperature of the water will determine the flow rate the unit puts out. Consult the flow charts on the last page of this manual to determine the possible outlet temperature and flow rate combinations.

Based on the United States Department of Energy method of testing water heater output, the Mobius is rated for 370 gallons per hour, or 6.0 GPM, at a 77° F rise above the inlet temperature. Refer to the following chart of typical household flow rates to determine what the Mobius can do in a household application. Remember that for bathing, cold water will be mixed for a comfortable temperature, increasing the flow output rate.

Household Flow Rates	
Appliance / Use	Flow Rate (GPM)
Lavatory Faucet	1.0
Bath Tub	4.0
Shower	2.0
Kitchen Sink	1.5
Dishwasher	1.5
Washing Machine	2.0

Taken from UPC 1997

Start Up

Once you have properly installed the unit, check the gas and water connections for leaks. Check for proper ventilation and combustible

air to the heater. **Purge the gas and water lines to remove Air pocket.**

Then follow these steps to turn on your unit.

1. Close the manual gas control valve located on the gas line.
2. Fully open the manual water control valve on the water supply line.
3. Open a hot water tap, to verify that water will flow to that tap. Then close the hot water tap.
4. Fully open the manual gas control valve installed.
5. Turn on the 120 volt 60 Hz power supply to the Flash Water Heater.
6. Now you are ready to enjoy hours of endless hot water.

TURN OFF GAS APPLIANCE

Close the manual gate valve on the gas inlet line. Then turn off the power supply



Manifold Gas pressure Port

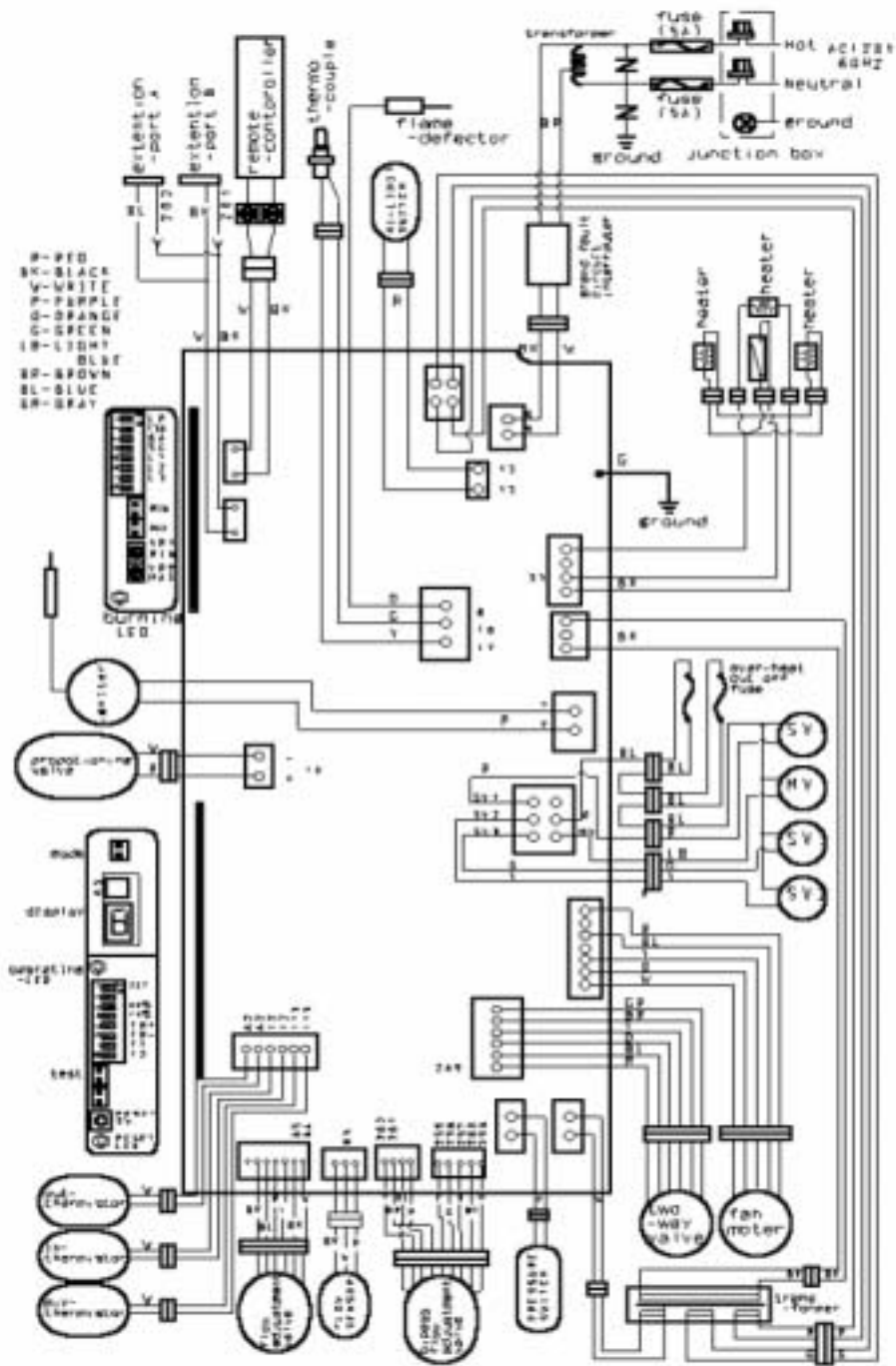

Wiring Diagram

A wiring diagram is located on the inside front panel of the appliance.

Electrical Rating: 120 VAC, 60 Hz, 0.8 A.

Note: If any of the original wiring supplied with this appliance must be replaced, it must be replaced with appliance wiring material (180c) or its equivalent. Wires are available through the manufacturer.

FOR YOUR SAFETY READ BEFORE OPERATING

WARNING: If you do not follow these instructions exactly, a fire or explosion may result causing property damage, personal injury or loss of life.

- A. This water heater does not have a pilot. It is equipped with an electronic ignition device that automatically lights the burner. Do not try to light the burner by hand.
- B. **BEFORE OPERATING** smell all around the water heater area for gas leaking. Be sure to smell next to the floor because some gas is heavier than air and will settle on the floor.

WHAT TO DO IF YOU SMELL GAS.

- Do not try to light any appliance.
 - Do not touch any electric switch, do not use any phone in your building
 - Immediately call your gas supplier from a neighbor's phone. Follow the gas supplier's instructions.
 - If you cannot reach your gas supplier, call the fire department.
- C. Use only your hand to turn the gas valve knob. Never use tools. If the knob will not turn by hand, don't try to repair it. Call a qualified service technician. Force or attempted repair may result in a fire or explosion.
 - D. Do not use this water heater if any part has been under water. Immediately call a qualified service technician to inspect the water heater and to replace any damaged parts.

OPERATING INSTRUCTIONS

1. **STOP!** Read the safety information above on this label and Owners Manual.
2. Turn off all electric power to the water heater.
3. Do not attempt to light the burner by hand.
4. Turn the manual gas valve located on the outside of the unit clockwise to the off position.
5. Wait five (5) minutes to clear out any gas. If you then smell gas. **STOP!** Follow "B" in the safety information above on this label. If you don't smell gas, go to next step.
6. Turn the manual gas valve located on the outside of the unit counter clockwise to the ON position.
7. Turn on all electrical power to the water heater.
8. If the water heater will not operate, follow the instructions " to Turn Off Gas to water heater" and Call your service technician or gas supplier.

TO TURN OFF GAS TO APPLIANCE

1. Turn off all electric power to the water heater if service is to be performed.
2. Turn the manual gas valve located on the outside of the unit clockwise to the off position.

DANGER



Vapors from flammable liquids will explode and catch fire, causing death or severe burns.
Do not use or store flammable products such as gasoline, solvents or adhesives in the same room or area near the water heater.

Keep flammable products:

1. Far away from heater.
2. In approved containers.
3. Tightly closed
4. Out of children's reach

Vapors:

1. Cannot be seen
2. Vapors are heavier than air
3. Travels a long way on the floor
4. Can be carried from other rooms to the main burner by air current.

WARNING: Do not install water heater where flammable products will be stored.

Read and follow water heater warnings and instructions. If owner's manual is missing, contact the retailer or manufacturer.

WARNING

The outlet hot water temperature of the MOBIUS water heater is factory set at 140 °F.
WARNING: Use this heater at your own risk. The set outlet water temperature can cause severe burns instantly or death from scalds. Test the water before bathing or showering.
Do not leave children or the infirm without supervised.



Hot Water Heater temperature over 125 °F can cause severe burns instantly or death from scalding.

Children, disabled and elderly are at the highest risk of being scalded.

Feel water temperature before bathing or showering.

Temperature limiting valves are available, ask professional person.

Applications

Space Heating Application

The FLASH T-K2 can be used for space heating as well as potable heating of hot water applications.

WARNING

- Toxic chemicals such as used for boiler treatments chemical, alcohol, glycerol and glycol group will not be introduced into the system when used for potable water and space heating.
- The FLASH T-K2 can be used to supply potable water and space heating and shall not be connected to any heating system or component(s) previously used with non-potable water where any chemicals were added to the water heating appliances.
- When the system requires water for space heating at temperatures higher than required for other used, a means such as a mixing valve shall be installed to temper the water for those uses in order to reduce scald hazard potential.
- Water temperature over 125 ° F can cause severe burns instantly or death from scalds.
- Chemicals such as diluted Glycol can be used for radiant floor, Hydro-warm air or Baseboard heating only.

Basic system drawings and Schematics.

Heating application only:

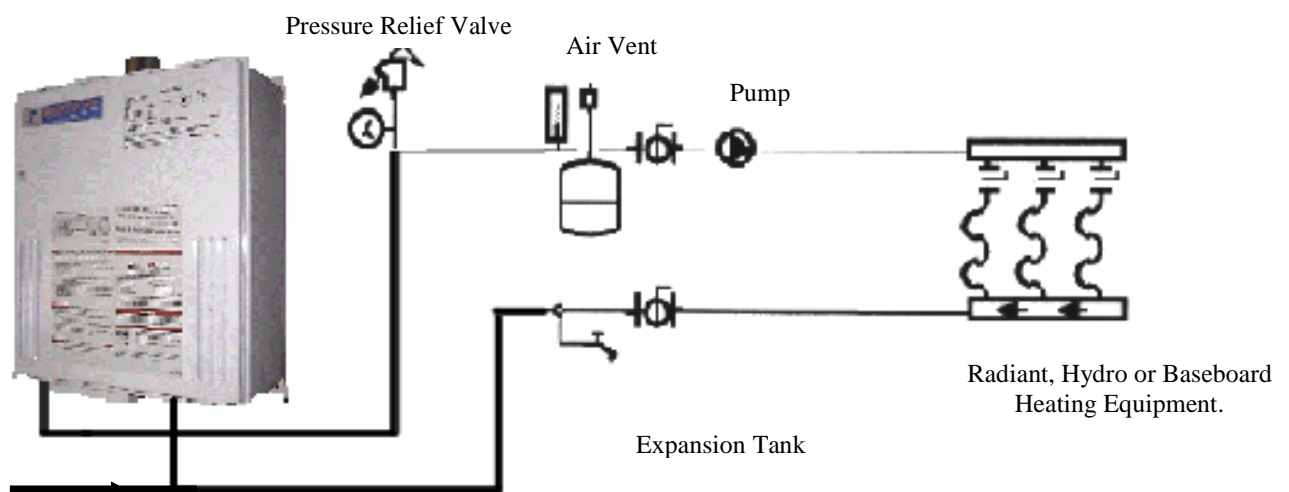

Make up Water Supply

Warning: This illustration is for concept only. There are a wide variety of variations to the application of controls and equipment presented applications. Designers must add all necessary safety and auxiliary equipment to conform to code requirements and design practice.

For more details, contact Technical Department at (888) 882-5244

Dual-purpose hot water heating (Domestic and Heating):

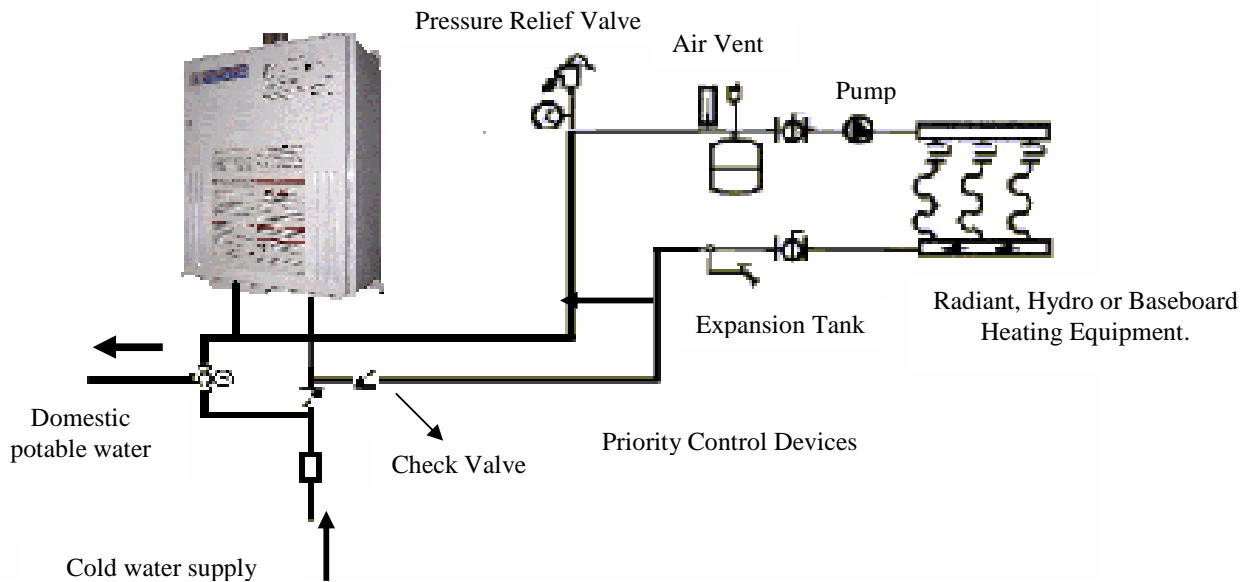

Priority Control Devices: It has a capability to make priority system that can be used as a controller flow sensor, Aquastat, or electronic controller to controlling radiant, Hydro or baseboard heating equipments.

Warning: Follow all local codes, or in the absence of local codes, follow the most recent edition of the National Standard Code, ANSI Z21. 10.3.

Warning: This illustration is for concept only. There are a wide variety of variations to the application of controls and equipment presented applications. Designers must add all necessary safety and auxiliary equipment to conform to code requirements and design practice.

For more details, contact Technical Department at (888) 882-5244

T-M1 with Storage Tank

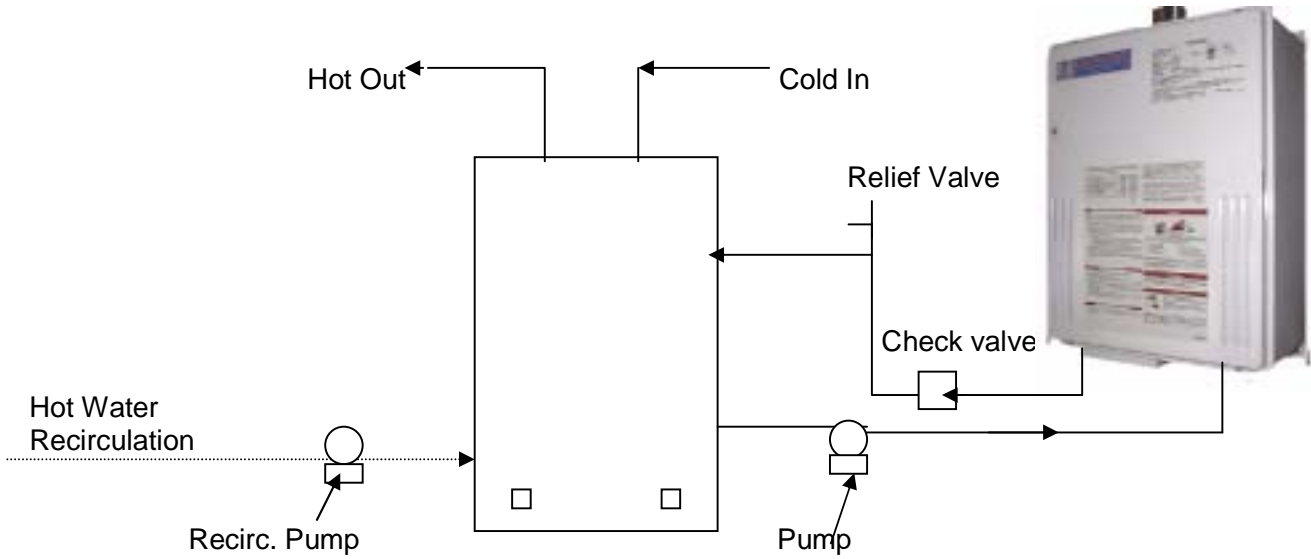

The maximum flow rate through the T-M1 is 9.6 GPM. If it is necessary to achieve higher flow rates for longer periods of time, then it can be installed in conjunction with a storage tank. A pump will be necessary to keep the water hot. We suggest a pump of 1/12 hp or greater depending on the system.

Recirculation

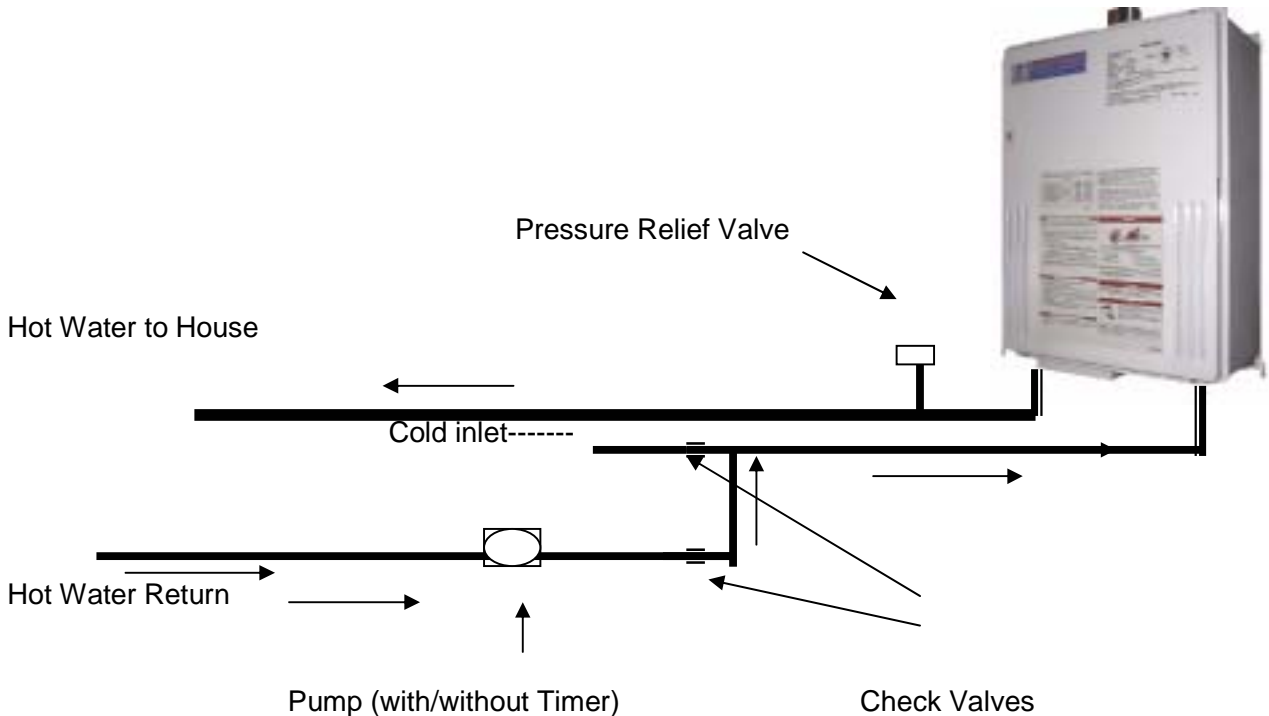

This system will also need a pump of 1/12 hp or greater, depending on the application situation. For more details, contact Technical department at (888) 882-5244

Hot Water Output Temperature Setting:

With the MOBIUS Water Heater output hot water temperature can be adjusted either with the optional remote controller (Part TM-RE10, from 95 °F to 176 °F) or manually from the main computer control boards dipswitch. Dipswitches can set four hot water output temperatures 113 °F, 140 °F, 167 °F, and 176 °F. (Factory set temperature; 140 °F)

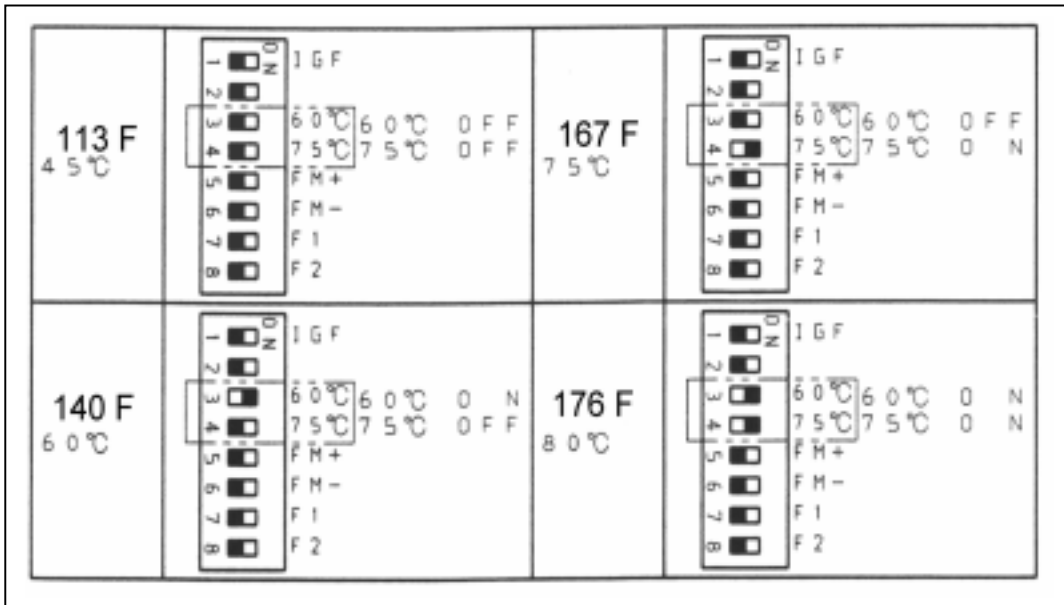

Manifold Multi-System Application for Large Volume.

MOBIUS Water Heater has full capability of manifold multi-systems, with Multi-System Computer Control (Optional Part TM-RE20). This Multi-System Computer Controller, you can manifold from 2 units to 20 units for commercial and residential application with each computer controller. One computer (Part TM-RE20) system can make from 26,000 BTU to 4.7 Million BTU system, with fully automatic modulation for large application

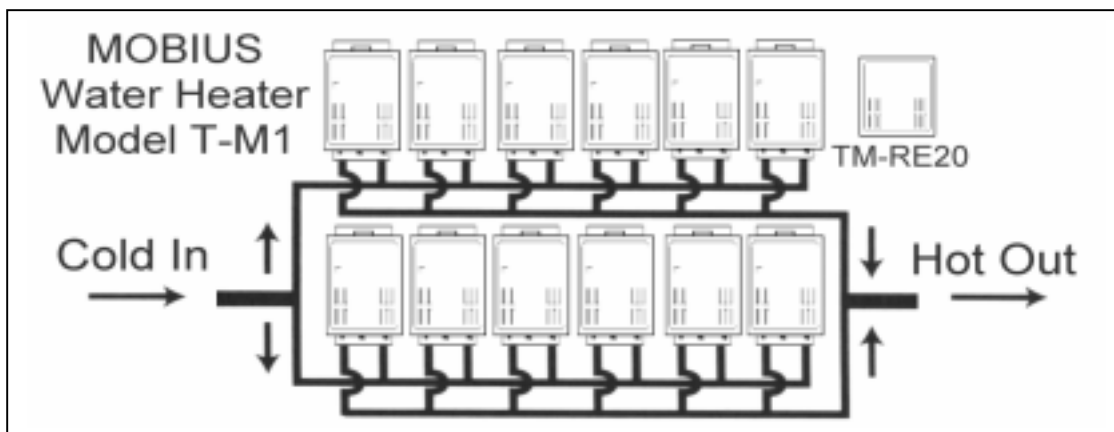

Electric Wiring: MOBIUS Water Heater™ Model T-M1 Electrical Load: Maximum 0.8 A, 120V per Unit.

Individual cut off switch, even though units have very low electrical load, recommended for multi-system for the purpose of maintenance.

Multi System

Main Multi System Controller (TM-RE20) and Temperature Remote Controller (TM-RE10) wiring:

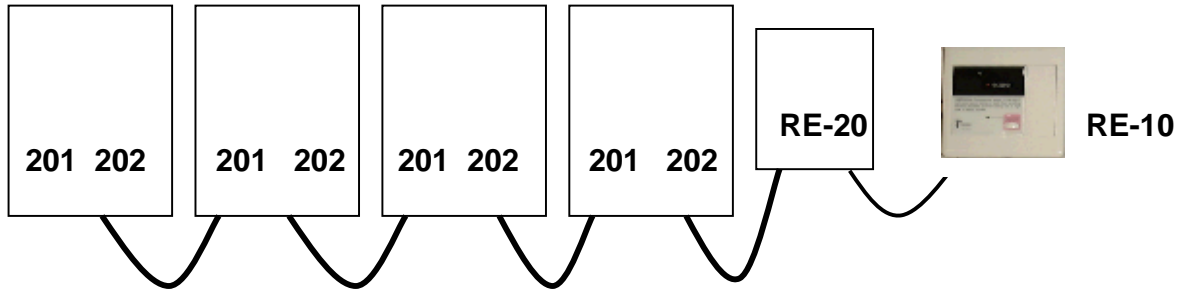

Detail Wiring: T-M1 Communications cables are inside Box for TM-RE20. TM-RE10 Cable can be use above 18 gage wire and up to 250 ft.

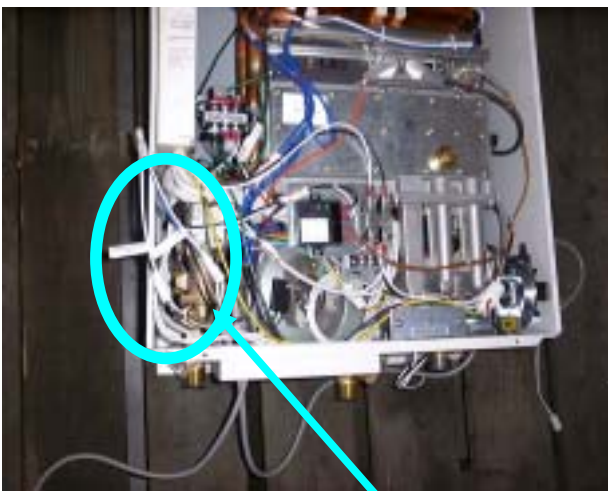

Wire No. 201 (Male Adapter) and No 202 (Female Adapter)

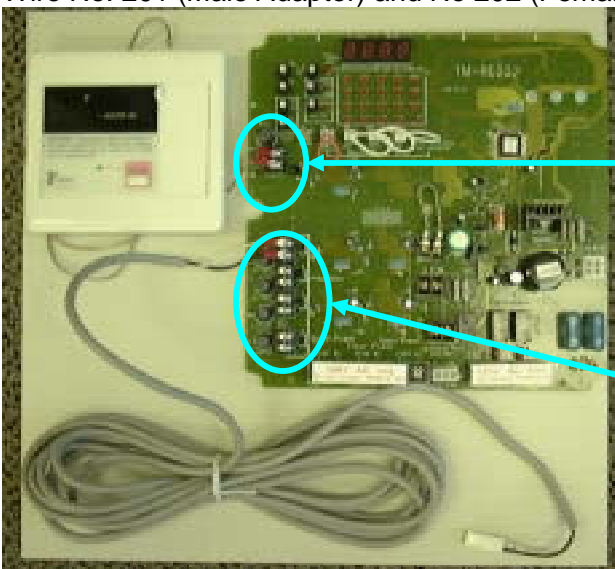

For TM-RE10 Port.
Use 18 Gage Wire.
No Polarity

It has four Ports.
Each port can connect up to Five T-M1.
No Polarity

Pump Connection:

MOBIUS Water Heater™ Main Multi System Controller will be maintaining setting temperature inside storage tank water with automatically T-M1 ON/OFF Mode.
Circulation Pump between T-M1 system and Storage has to be ON (running) 24- Hour, it will maintain set temperature.

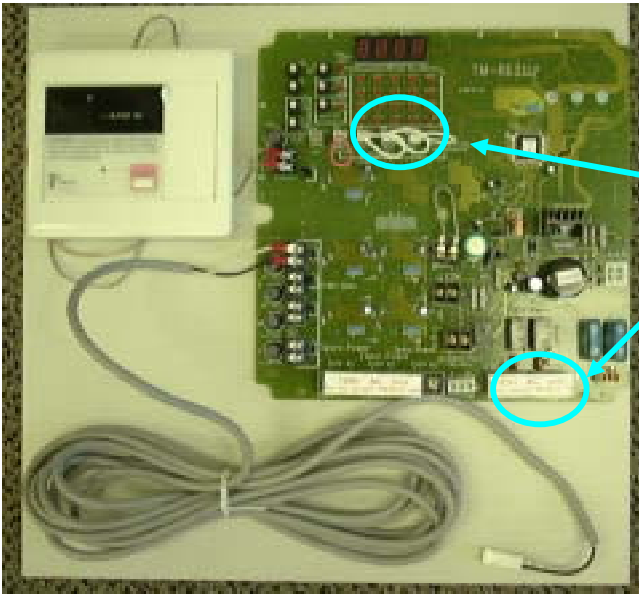

Pull out jump cable for Store for activates power port.
Needs power relay for using this application

Final Check of the Multi-System: From MOBIUS Water Heater™ Model T-M1 Computer Board, it has a jump cable for Single mode or Multi mode. To switch to Multi mode, this jump cable has to be removed from the T-M1 computer board permanently, but please keep this jump connector safety stored for future maintenance (this jumper is located behind the “do not remove” label.



Firing System: Power on each T-M1 and TM-RE20, then TM-RE10 will show Number 0000 for 20 to 25 second. Next, the RE-10 will show a default temperature setting of 108F this can be changed with HOT and COLD button located on the TM-RE10. If you press the ON/OFF button this time, RE10 shows current TIME that can be changed, refer to the instructions provided with the TM-RE10. After setting of the TIME, press the ON/OFF button, RE-10 will show current Temperature setting.

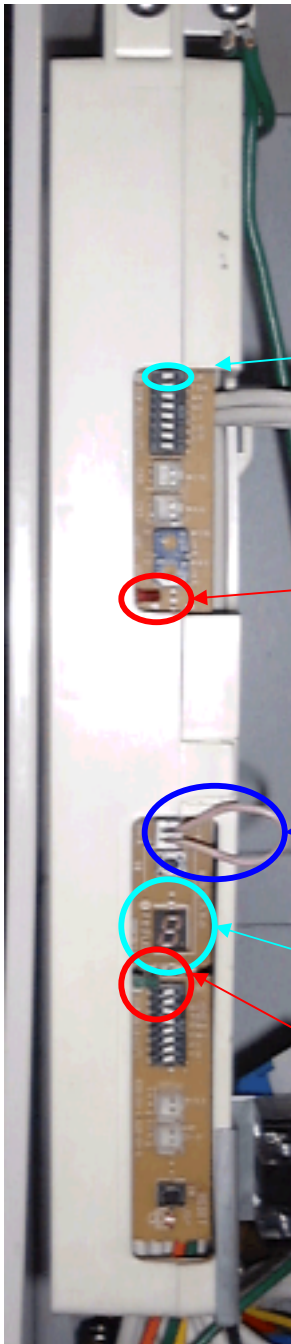

LP or Natural Gas, Please don't change these switch, Factory already set it correctly.

When unit is firing, this RED LED will be ON

For Single or Multi mode JUMP cable. For Multi mode, permanently pull out.

Error signal LED, this LED shows for unit error, also it will show on RE-10 and RE20. Error codes are in Installation Manual Boor.

Standby Light with Green LED, ON light mean Unit is ready to fire. When Unit is ON, upper RED LED will be ON also.

Maintenance and Service

WARNING: Turn off the electrical power supply, the manual gas control valve, and the manual water control valve before servicing.

Do this immediately after installation.

1. Cleaning the Cold-water inlet filter, refer to figure below.
2. Be sure that all openings for combustion and ventilation air are not blocked.
3. Check that the exhaust vent pipe is not blocked.
4. Check the gas pressure.
5. Keep the area around the water heater clear. Remove any combustible materials, gasoline or any flammable vapors and liquids.

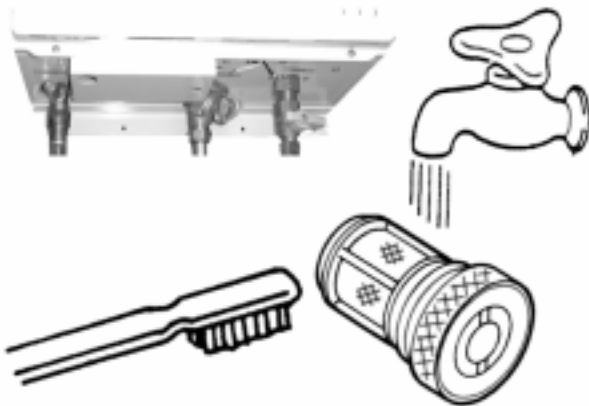

The unit should be checked once a year or as necessary by a certified and trained technician. If repairs are needed, any repairs should be done by a certified and trained technician.

The following systems and parts should be checked at least once a year:

1. Venting systems
2. Burners
3. Manual operation of the pressure relief valve to ensure correct operation.
4. Periodic cleaning of the water filter, refer to figure below.
5. Heat exchanger. Remove the Thermistor and check for a mineral coating. A mineral coating on the Thermistor requires flushing the heat exchanger with a de-scaling

solution. Scale build up will void your warranty and shorten the life of your water heater.

Common Trouble Shooting

Water Isn't Hot Enough

The T-M1 can burn gas at a maximum input rate of 235,000 BTUH. This puts a limit on the possible output temperature and flow capabilities (See flow chart on the last page of this manual). If the water doesn't seem hot enough, compare the flow and temperature that is being attained to the T-M1 flow vs. temperature chart. If the unit is not performing according to the chart, first check that the gas supply line is sized properly, and that the gas pressure is within the required range. If the gas line is okay, check the plumbing for mixing valves, thermostatic valves, scald protection, single handled valves or crossed connections. If the unit is performing in accordance with the flow chart, then it may be undersized for the application. If the unit is performing according to the chart, the output temperature can be adjusted using the TM-RE10 or with the dipswitches on the unit.

It Takes Too Long to Get Hot Water

The T-M1 takes three seconds to ignite, and three more to get up to temperature. The rest of the time needed for hot water to get to a fixture is due to the length of piping between the water heater and the fixture. If the unit seems to be taking longer than six seconds to initiate, check the filter and flow sensor for any debris or damage.

The T-M1 Will Not Initiate

First check the flow rate through the unit. If the flow is not .75 GPM or greater, the unit will not initiate. Check the filter and the flow sensor for any debris or damage.

Press the lower green button on the GFCI inside the unit. If the red light above it does not come on, then there is a problem with the electrical supply to the unit. If that light does

come on, hit the green reset button above the light, and look for the green light on the circuit plate at the top left of the unit. If this light is not lit, there is a problem with the electrical connection between the GFCI and the circuit plate. Contact Takagi Industrial Company for Instructions.

Error Codes

All Takagi units are self diagnostic for errors. If there is a problem with the installation or the unit, it will give a signal, through a pair of flashing lights on the circuit plate or error display on circuit board LED display to communicate the source of the problem. If the unit has a TK-RE10 remote control installed, this will give also give a numerical error code. Consult the following chart for the meaning of an error code:

MOBIUS Water Heater Model T-M1 has a built in self-diagnostic computer programmed for safety and convenience for trouble shooting and maintenance service.

AT the T-M1 Computer Board, a numeric display will notify of any error displaying a numeric code when the MOBIUS water heater has or encounters a problem. This numeric code will give symptoms for trouble shooting service and maintenance service.

The T-M1 consists of five major components: Temperature control, Gas control, Water control, Burner Control, and Main computer control.

Error NO.	Component
031,141,711,741,751	Main Computer Control
701	Temperature Control (Setting Temp. + over 50 °F)
111, 121	Burner Flame
311, 321,331	Temperature control
391,611,721,991	Burner control
501	Gas control
651, 661,541	Water control
101	Combustible Air

More detail error code can be found at Trouble shooting Diagnose Flow Chart.



TK-RE10

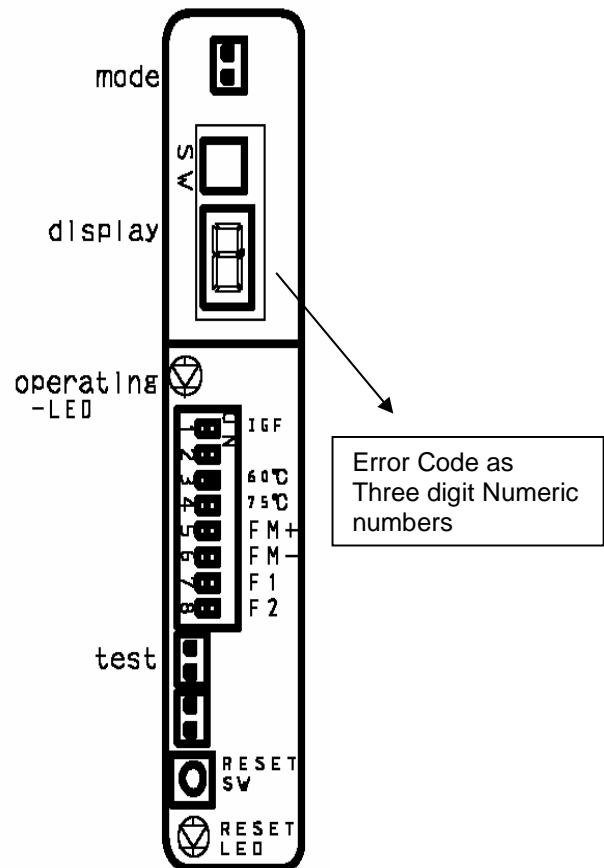

**MOBIUS
Water Heater
Model T-M1
Trouble Shooting
Diagnose
Flow - Chart**

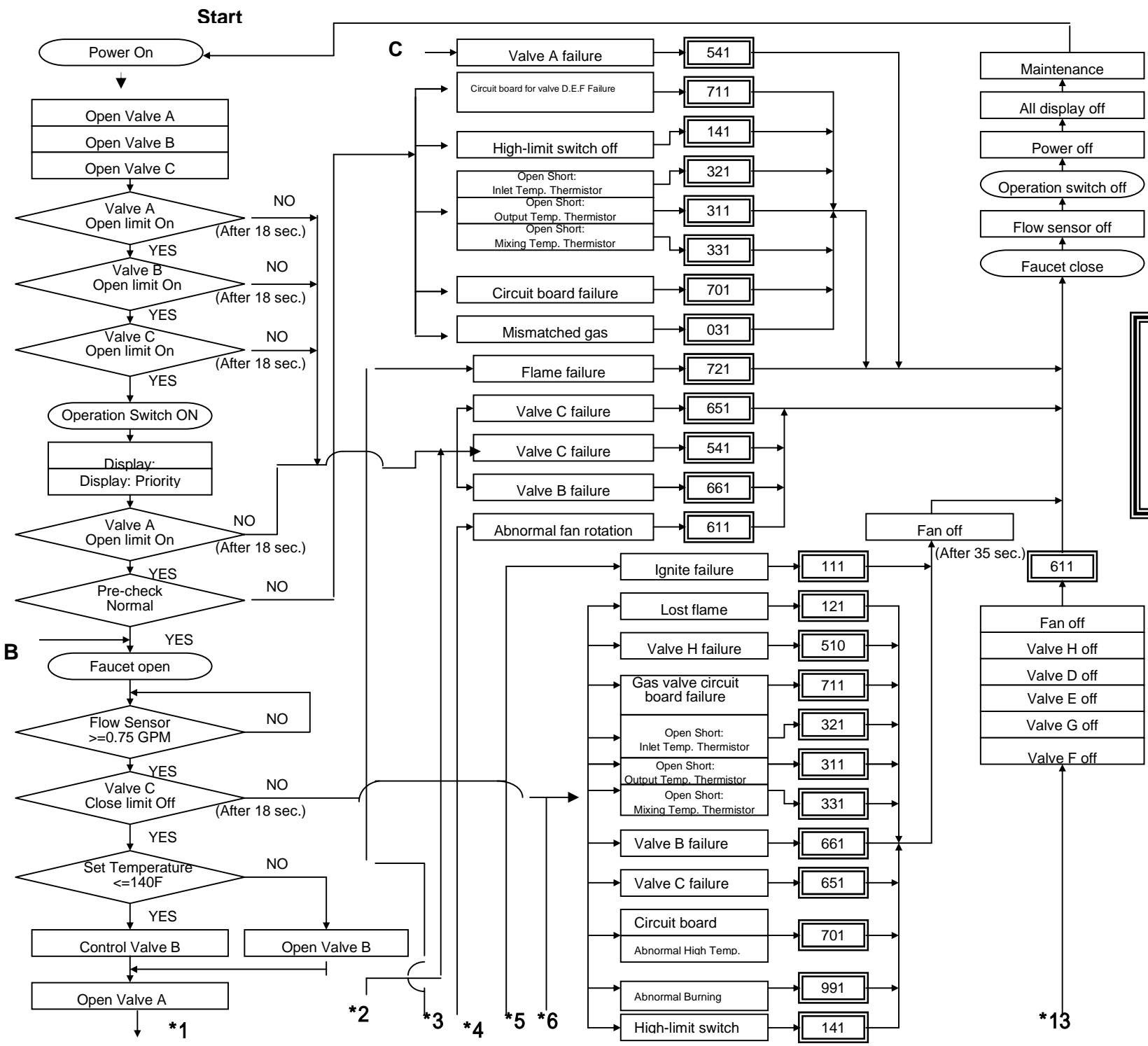

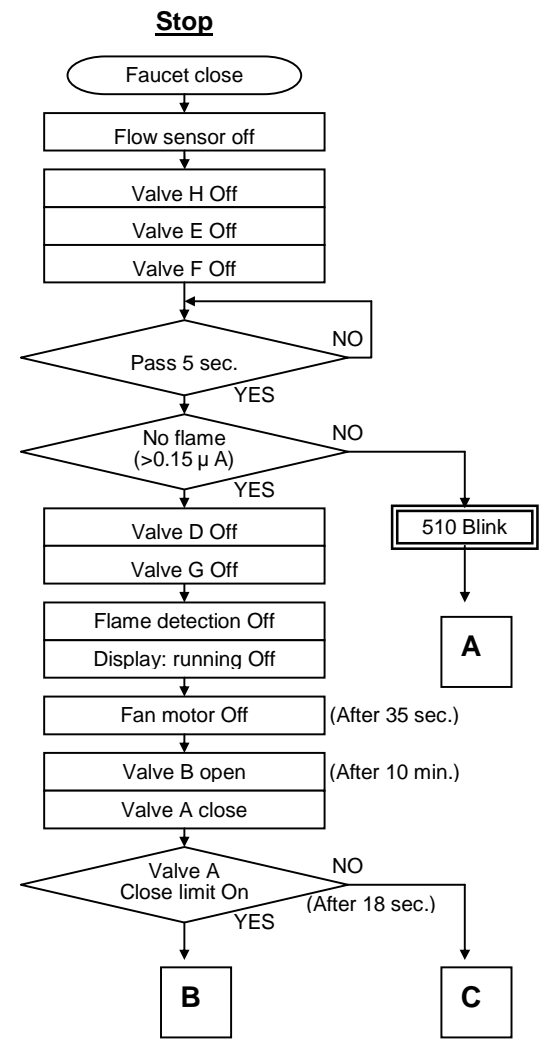
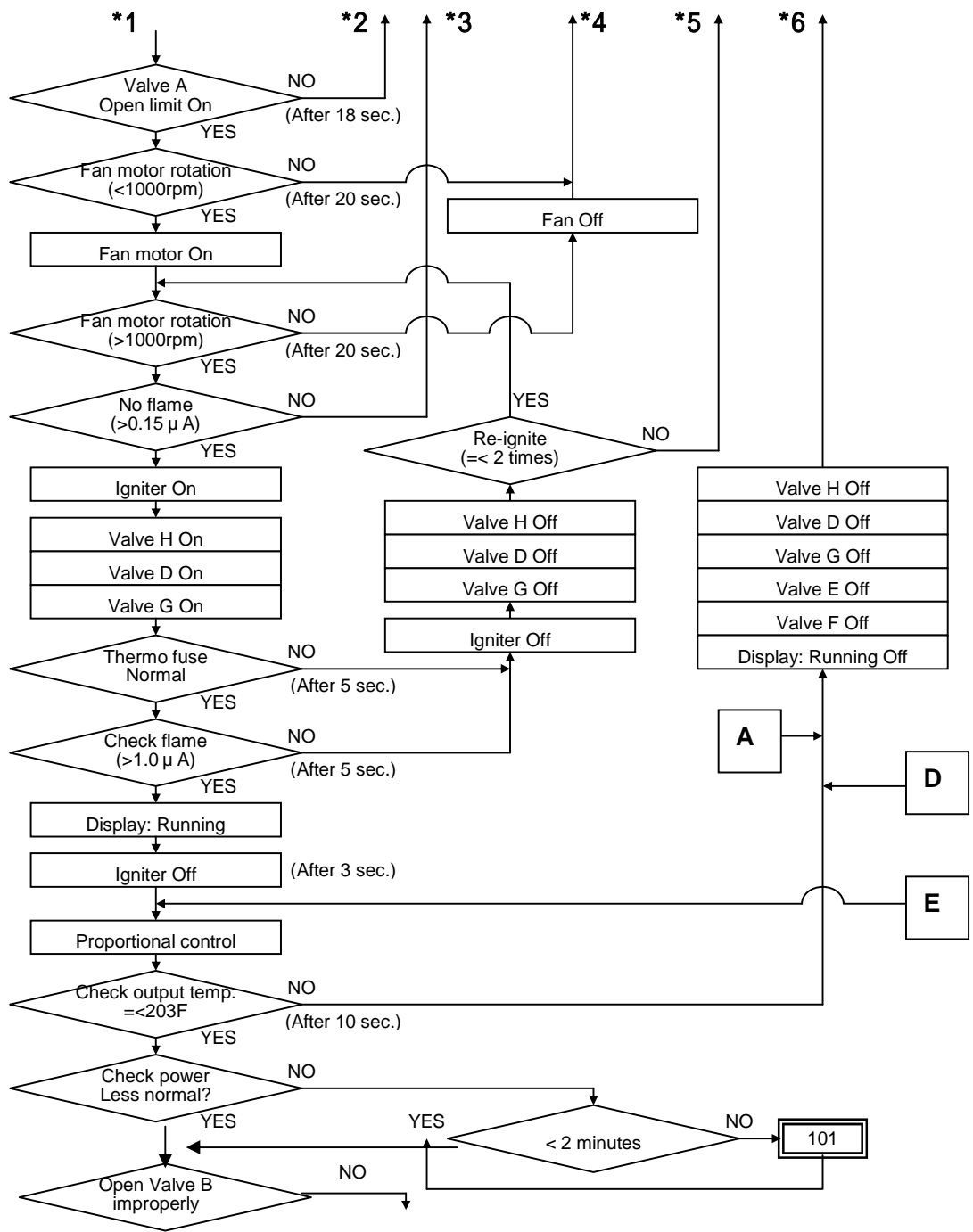

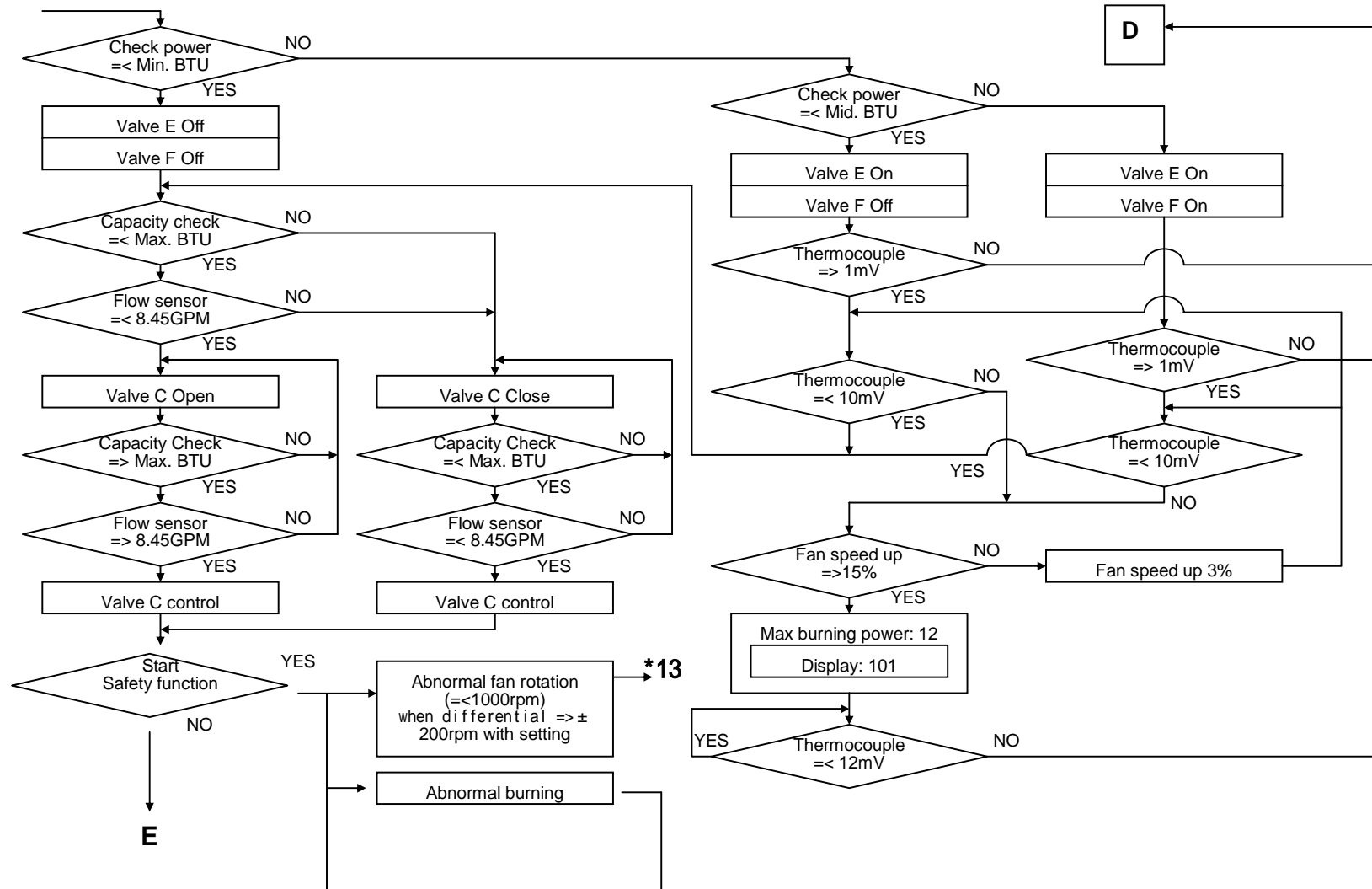
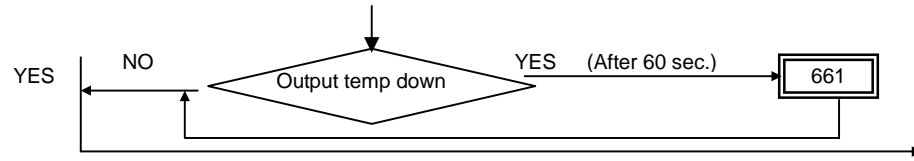

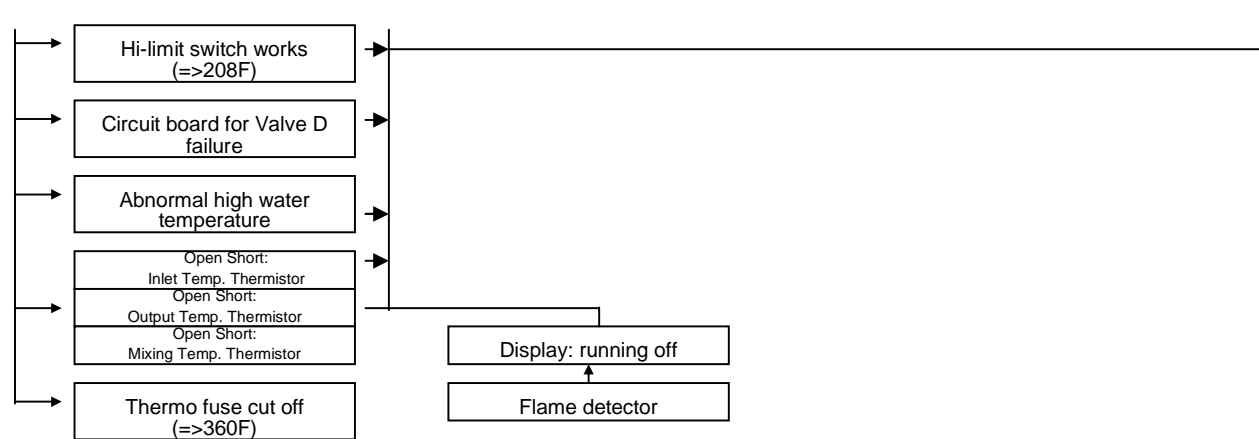

<Water Valve>

- Valve A Water Outlet Valve (Two way valve)
- Valve B By-Pass Water Control Valve
- Valve C Water Control Valve

<Gas Valve>

- Valve D Solenoid Valve 1**
- Valve E Solenoid Valve 2
- Valve F Solenoid Valve 3
- Valve G Proportional Valve
- Valve H Gas Inlet Valve

Error	Symptom	Error	Symptom	Error	Symptom
31	Wrong Gas Type	331	Mixing Thermistor Fail	701	Abnormal Mixing Thermistor
101	Insufficient Gas Supply	391	Abnormal Thermocouple	711	Abnormal Gas Solenoid Valve
111	Ignition failed	510	Abnormal Main Gas Valve	721	Computer Pre-post Check Problem
121	Loss Flame	541	Abnormal Two-Way Valve	741	Main remote control Trouble
141	Hi-Limit Switch Trip	611	Abnormal Fan Motor	751	Temperature Remote control Trouble
311	Output Thermistor Fail	651	Abnormal Bypass Valve	761	Multi-system Controller
321	Inlet Thermistor Fail	661	Abnormal Output Adjust Valve	991	Abnormal Burning
211	Vent Pipe	441	Flow Sensor		

MOBIUS Water Heater Parts List and Component Diagram

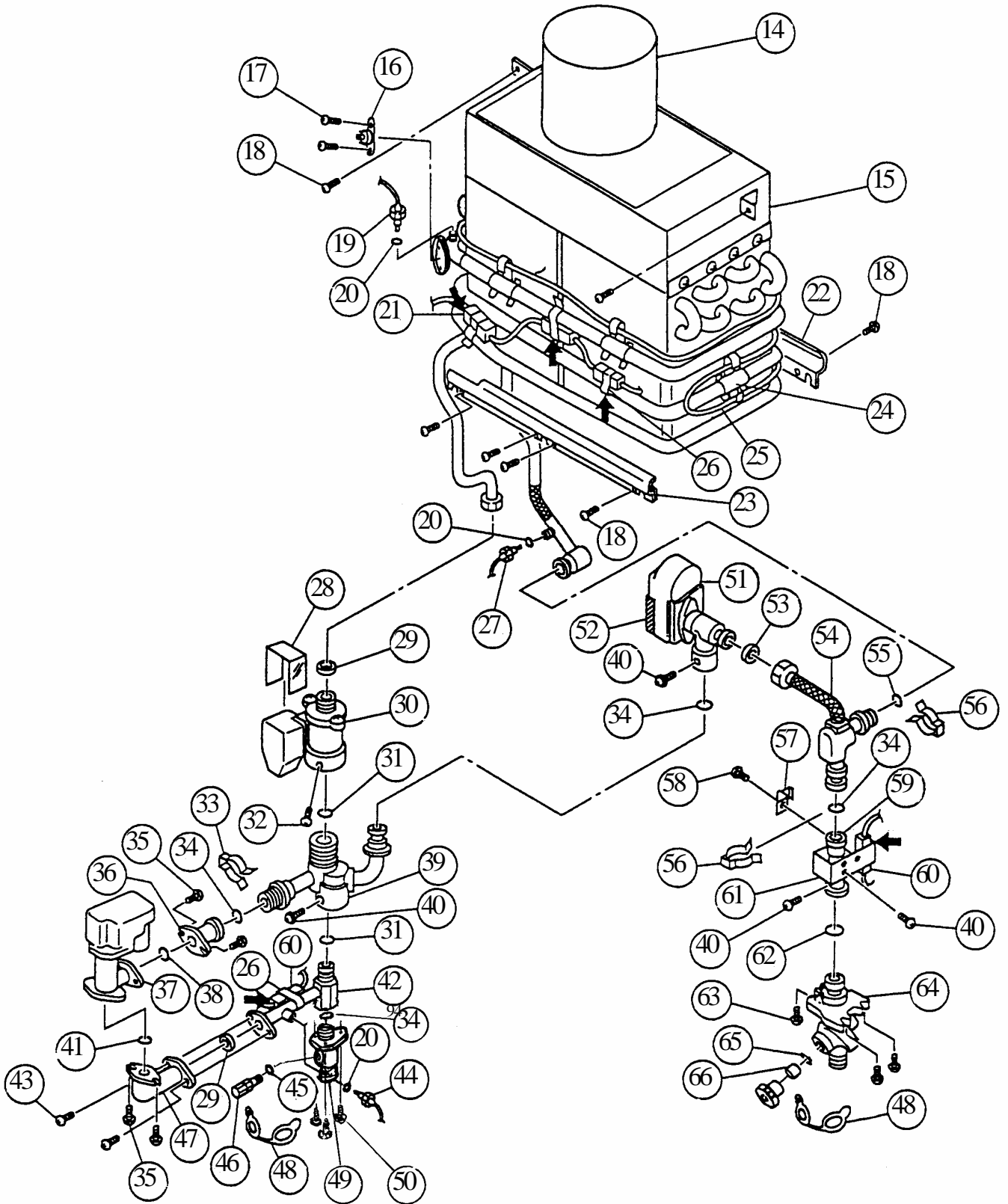

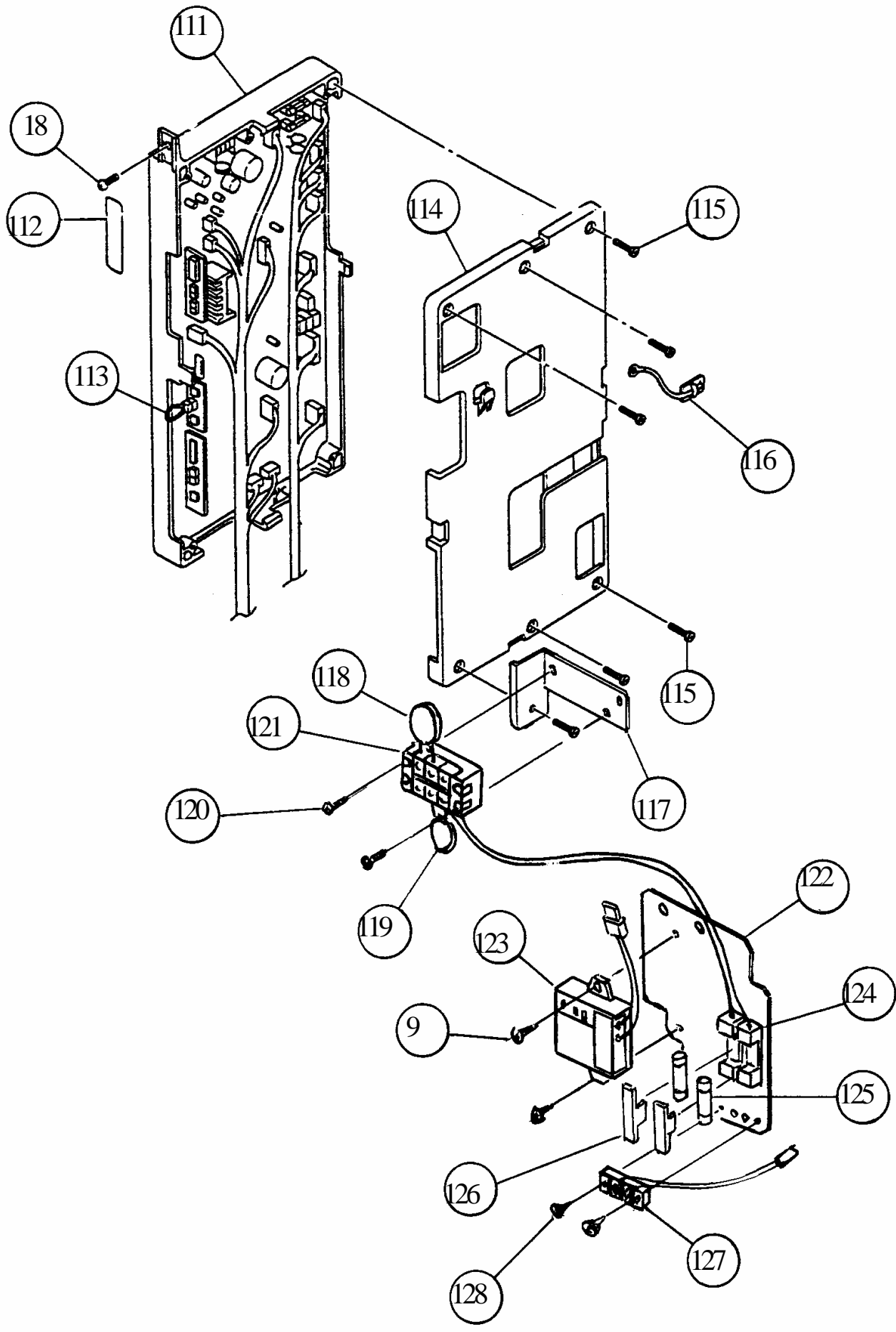

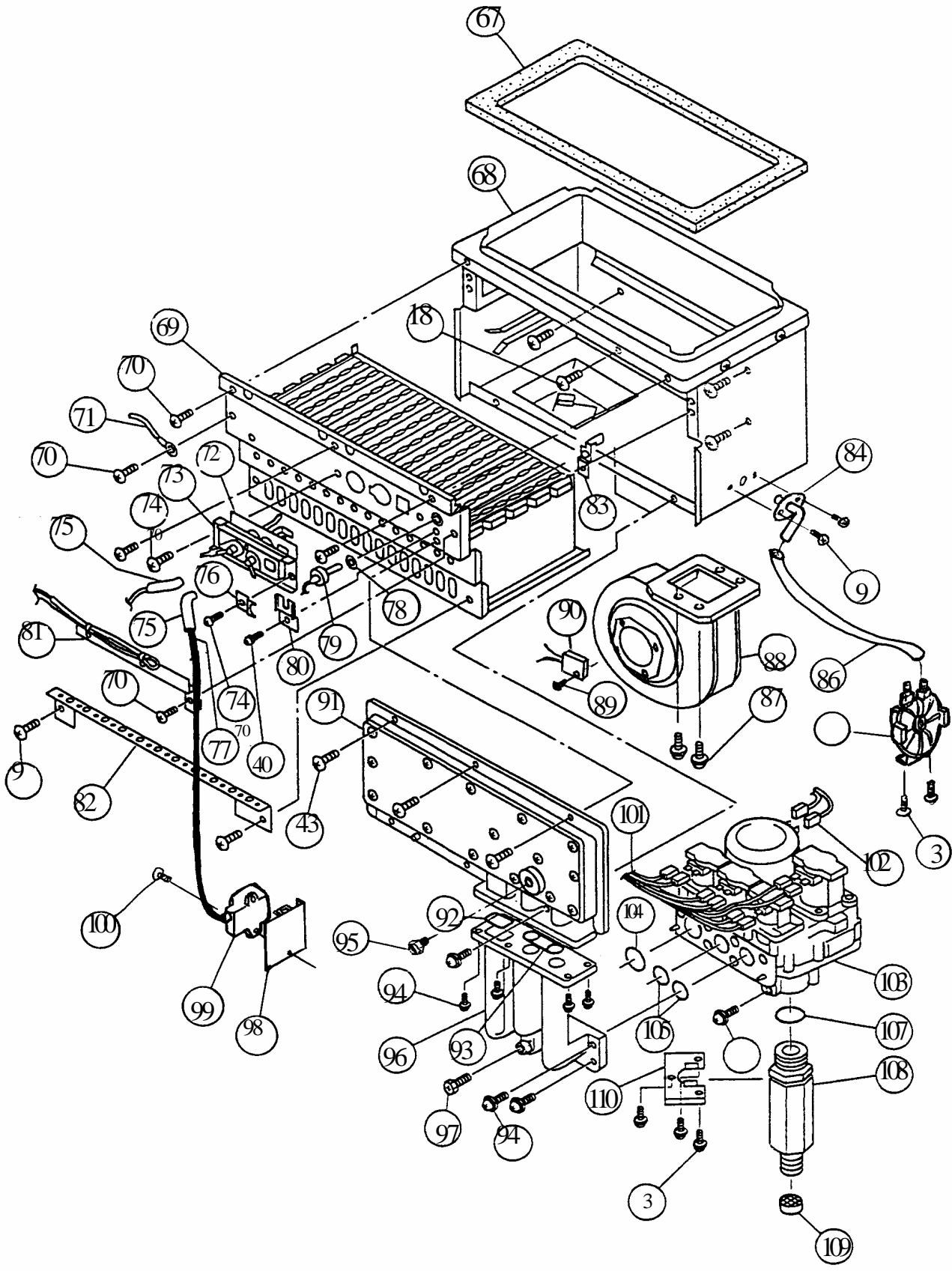

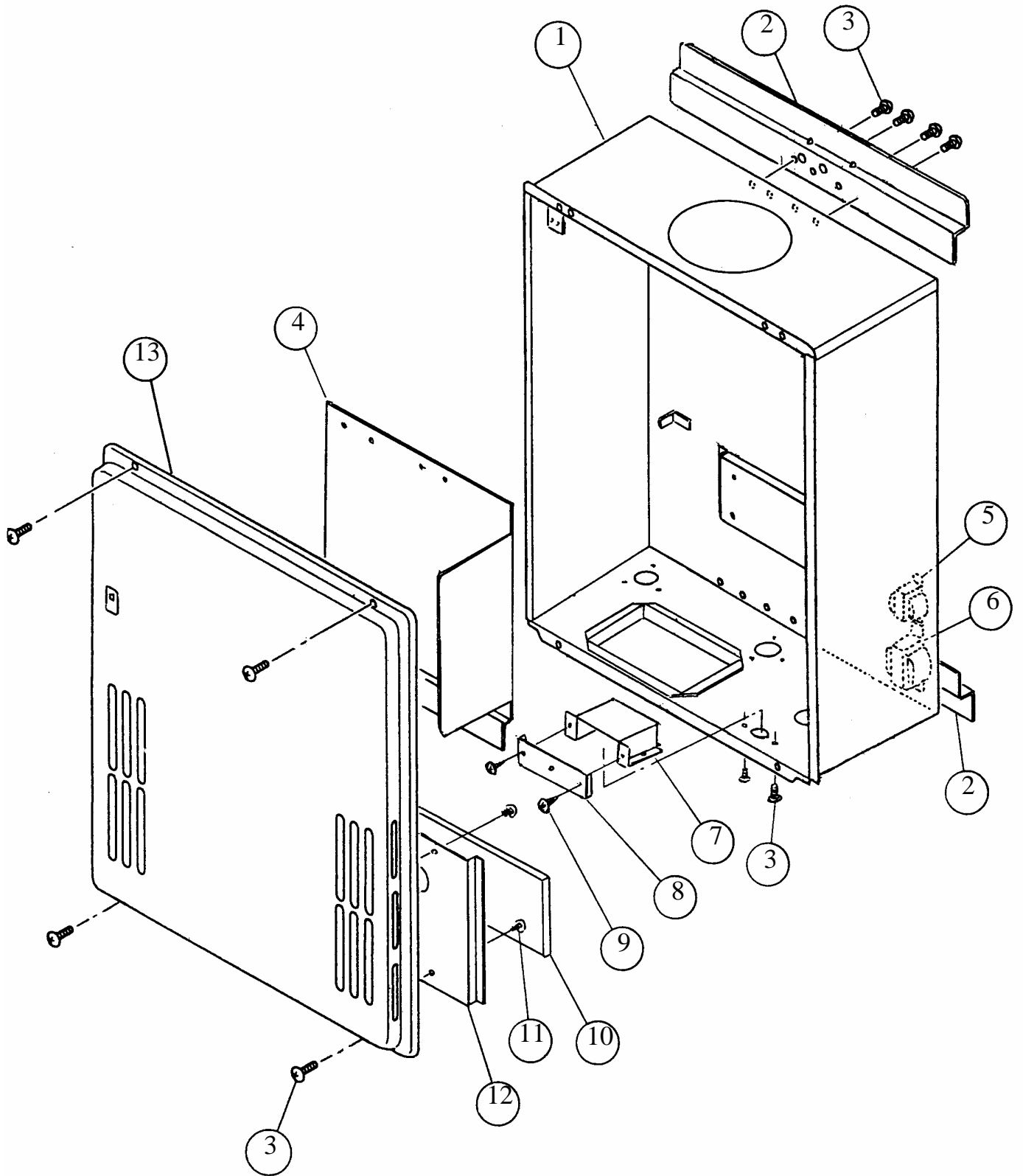

Parts List

Part No.	Description	Part No.	Description
1	Case Assembly	65	O-ring P25
2	Brackets	66	Filter
3	Screw (W) M4 x 10	67	Packing
4	Back Guard Panel	68	Combustion Chamber
5	Transformer	69	Burner Assembly
6	Transformer	70	Screw M4 x 12
7	Junction Box	71	Wire Holder
8	Junction Box Cover	72	Spark Electrode Holder Packing
9	Screw M4 x 8	73	Spark Electrode Holder
10	Sound Insulation	74	Screw M4 x 10
11	Screw M4 x 8 (Coated)	75	Silicon Cap
12	Weather Protection Panel	76	Spark Electrode Fixing Plate
13	Front Cover	77	High Voltage Igniter Cable
14	Exhaust Pipe	78	O-ring (seal)
15	Heat Exchanger Assembly	79	Thermocouple
16	Hi-Limit Switch	80	Thermocouple Fixing Plate
17	Screw M3 x 6	81	Overheat Cut Off Fuse
18	Screw M4 x 10 (coated)	82	Damper
19	Outlet-Thermistor	83	Washer
20	O-ring P4	84	Pressure Switch Port
21	Heater Block 604	85	Silicon Tube
22	Heat Exchanger Fixing Plate (Back)	86	Pressure Switch
23	Heat Exchanger Fixing Plate (Front)	87	Fan Motor
24	Over Heat Cut Off Fuse Fixing Plate	88	Screw M4 x 12 Hex
25	Over Heat Cut Off Fuse	89	Thermostat
26	Heater Block Fixing Plate	90	Screw (W) M3 x 10
27	Inlet-Thermistor	91	Manifold
28	Two Way Valve Cover	92	Manifold Gas Pressure Port
29	Silicon O-ring M26	93	Gasket
30	Two Way Valve Assembly	94	Screw M4 x 12
31	O-ring P20	95	Manifold Gas Pressure Tap
32	Screw M4 x 8	96	Gas Coupling
33	Quick Release Plate	97	Screw M4 x 8 (Washer & Hex head)
34	O-ring JASO#1017	98	Igniter Fixing Plate
35	Screw M4 x 12	99	Igniter

36	Flange	100	Screw M4 x 6
37	Flow Adjustment Valve	101	Solenoid Valve Wire
38	O-ring P16	102	Proportional Valve Wire
39	Bypass Junction	103	Gas Valve Unit
40	Screw M4 x 6	104	O-ring P22
41	O-ring P18	105	O-ring P18
42	Water outlet Connection	106	Screw M4 x 8
43	Screw M4 x 14	107	O-ring P26
44	Mixing Thermistor	108	Gas Inlet
45	O-ring P6	109	Gas Filter
46	Drain Plug	110	Gas Inlet Fixing Plate
47	Mixing Connection	111	Computer Board
48	Drain Plug Band	112	Computer Board Sticker
49	Water Outlet	113	Mode Port
50	Screw (W) M4 x 12	114	Control Box
* 51	Bypass Flow Adjustment Valve	115	Screw M3 x 25
* 52	Bypass Valve	116	Wire Holder
53	Silicon O-ring M22	117	Terminal Holder
54	Bypass Connection	118	Surge Absorber: A
55	O-ring JASO3#1017	119	Surge Absorber: B
56	Clamp	120	Screw M4 x 16
57	Heater Fixing Plate	121	Terminal
58	Screw M4 x 6	122	Power Distribution Plate
59	Flow Sensor	123	Ground Fault Circuit Interrupter
60	Heater 102	124	Fuse Box
61	Magnetic Protection Plate	125	Fuse
62	O-ring JASO#1019	126	Fuse Cover
63	Screw M4 x 14 (coated)	127	Remote Control Terminal
64	Water Inlet	128	Screw M3 x 12

Out Put Temperature vs. GPM (Max. 9.6 GPM) with Various Ground Water Temperature
Correct Gas pipe size can be expect this chart

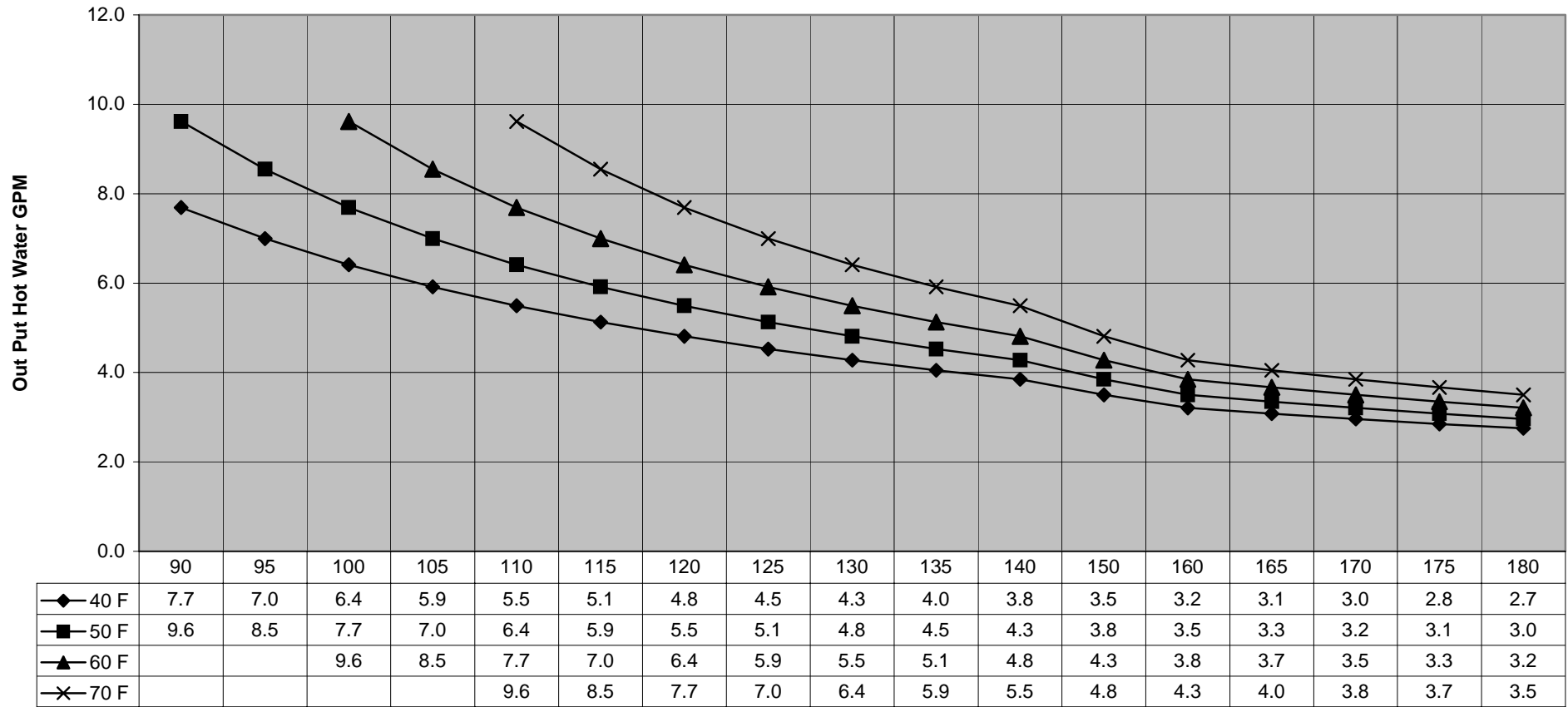

◆ 40 F ■ 50 F ▲ 60 F × 70 F